



SEARCHER PLUS
GT

**OPERATION
MANUAL**



TRILITHIC
INNOVATIVE ENGINEERING



TRILITHIC

Trilithic, Inc. was founded in 1986 as an engineering and assembly company providing customized communications and routing systems for business and government applications. As business expanded, Trilithic broadened its offerings by acquiring components manufacturer Cir-Q-tel and instruments manufacturer Texscan, adding broadband solutions to the product line.

Today, Trilithic is comprised of three major divisions, Broadband/CATV Instruments & Systems, RF Microwave Components, and Emergency Alert Systems. The Instruments Division offers Test, analysis and quality management solutions for the major cable television systems worldwide. The Division specializes in the design and manufacturing of portable RF test equipment and integrated test systems performing in a wide range of HFC and LAN applications. The Wireless division provides components and custom solutions for companies specializing in cellular, military and other wireless applications. The EAS Division is a leading supplier of government-mandated Emergency Alert Systems used by HFC service providers.

An industry leader providing telecommunications solutions for major broadband and wireless markets around the world, Trilithic is dedicated to providing quality products, services and communications solutions meeting or exceeding our customers' expectations. Today, from our worldwide headquarters in Indianapolis Indiana, we provide over 1500 measurement products and communications components to thousands of customers around the world.

TWO YEAR WARRANTY

Trilithic, Inc. warrants that each part of this product will be free from defects in materials and workmanship, under normal use, operating conditions and service for a period of two (2) years from date of delivery. Trilithic, Inc.'s obligation under this Warranty shall be limited, at Trilithic, Inc.'s sole option, to replacing the product, or to replacing or reporting any defective part, F.O.B. Indianapolis, Indiana; provided that the Buyer shall give Trilithic, Inc. written notice.

Batteries are not included or covered by this Warranty.

The remedy set forth herein shall be the only remedy available to the Buyer under this Warranty and in no event shall Trilithic, Inc. be liable for incidental or consequential damages for any alleged breach of this Warranty. This Warranty shall not apply to any part of the product which, without fault of Trilithic, Inc., has been subject to alteration, failure caused by a part not supplied by Trilithic, Inc., accident, fire or other casualty, negligence or misuse, or to any cause whatsoever other than as a result of a defect.

Except for the warranty and exclusions set forth above, and the warranties, if any, available to the Buyer from those who supply Trilithic, Inc., there are no warranties, expressed or implied (including without limitation, any implied warranties of merchantability of fitness), with respect to the condition of the product or its suitability for any use intended for it by the Buyer or by the purchaser from the Buyer.

 **TRILITHIC**
9710 Park Davis Drive
Indianapolis, IN 46235

Phone: (317) 895-3600
Toll Free in North America: (800)344-2412
Fax: (317) 895-3613

www.trilithic.com



INDEX

General Information

Introduction	3
Optional Accessories	5

Overview

Introduction	7
Identify Components	7
Front Panel	8
Rear Panel	11
Power Source	12
Battery	12
Mobile Mount Installation	12
Location	13
Electrical Connection	13
Vehicle Antenna	14

Application

Introduction	15
Leakage Monitoring	16
Mobile Patrol	16
Relative vs. Absolute Readings	16
Variable Effects	16
Variable Problems Solution	17
Localizing the Source	21
Leakage Measurement	22
Operational Tips	24
Use with CW or FM Carriers	24
Adjust Squelch	25

Calibration

Introduction	27
Calibration Procedure	27
Test Equipment	28
Test Setup	28
Test Setup Hookup	29

Calibration Check	30
Procedure	31
Attenuator x10	33
Set Squelch	34
Battery Check	34
Test Signal Levels	36

Additional Information

Specifications	37
----------------------	----

GENERAL INFORMATION

1

Introduction

Congratulations! You now own Trilithic's **Searcher Plus GT**; the advanced version of the original Searcher Plus. This instrument is the first leakage measurement receiver built specifically for systems employing digital set top terminals that cannot tolerate "tagged" leakage carriers. The Searcher Plus GT enables you to utilize the full range of leakage management functions from detection to location to CLI measurements; even in areas where electrical interference renders other detectors unusable. Features include:

- High resistance to "false alarms" from noise and overbuilt systems
- No tagging signal required
- Calibrated scale and audio alarm
- Compatible with Searcher Plus mobile mount and accessories

Interference from electrical noise or overbuilt systems can make it difficult to find and measure leakage. "Channel tagging", adding a special identifying modulation to the carrier used for leakage detection, is commonly used to increase resistance to interference. However, some digital set top terminals cannot tolerate tagged signals. In this situation, the Searcher Plus GT is the ideal alternative. The GT provides enhanced "false alarm" resistance and many of the features of Trilithic's **Super Plus**; without the use of a tagged leakage test signal. New patent pending circuitry in the Searcher Plus GT analyzes detected RF energy which automatically rejects all noise and signals that are not caused by leaks from your system.

Like the original Searcher Plus, the GT provides calibrated readings in microvolts/meter (uV/m) for CLI measurements. It is equipped with an audio tone of which the pitch varies with the strength of the detected leak.

For safety purposes, the Searcher Plus GT includes a peak hold function. This retains the peak reading until you are able to observe it.

The Searcher Plus GT can be used as a portable unit or mounted in a vehicle.

When used as a portable or hand-held unit, the Searcher Plus GT is powered from its internal rechargeable NiCad battery. You can connect a rubber duck antenna to the unit to locate leaks. You may also use the calibrated 50 Ohm dipole antenna to take absolute field strength measurements in uV/m.

The Searcher Plus GT uses the standard Searcher Plus mobile mount; a unique mobile adaptor which connects charging current and an externally mounted antenna to the instrument's rear panel. When placed in this mobile mount, the unit powers itself from the vehicle's electrical system, charges its internal battery and connects to a vehicle mounted antenna automatically.

CAUTION: When the Searcher Plus GT is used in the mobile mount, you should NOT use the cigarette lighter as a battery charger since the battery will discharge when the cigarette lighter is turned off.

By using the mobile mount, you can monitor for leaks from your vehicle while maintaining a "ready charge" on the unit's internal battery pack. Once a leak has been discovered by the visual meter indication on the meter or by an audio alarm, the Searcher Plus GT can be taken from the mobile mount to the leakage source for near field investigation using the flexible rubber duck antenna or optional near field probe for close-in inspection and fault diagnoses.

NOTE: When you are viewing the meter, look straight at the dial with your eye positioned at mid-scale. Do NOT follow the curve of the meter dial.

For measurements made at distances other than three meters (10 feet), the range indicator can be used. Signal peaking is simplified by direct readings in microvolts per meter and the peak hold detector.

Optional Accessories

The following accessories are available for your Searcher Plus GT:

- APM-2 permanent mount, vertical antenna 88-118 MHz
- APM-3 permanent mount, vertical antenna 118 -160 MHz
- AVM-2 magnetic mount, vertical antenna 88-118 MHz
- AVM-3 magnetic mount, vertical antenna 118-160 MHz
- AFS-2 50 Ohm calibrated dipole with insulated telescopic pole
- NFP-1 passive 50 Ohm near field probe
- ZMT-57 low loss 50 to 75 matching transformer

OVERVIEW

Introduction

Now that you have the Searcher Plus GT out of its box, take a few moments to look it over so that you become familiar with its controls.

NOTE: Searcher Plus GT, Leakage Receiver, Unit and Meter are used interchangeably throughout this manual.

Identify Components

The Unit has connectors and switches on the front and rear panels.

WARNING: Keep the Unit away from the antenna's magnet. It may damage your Meter.

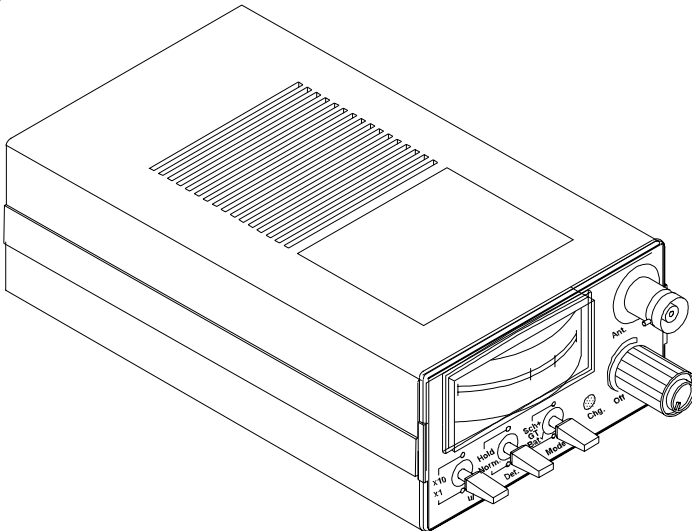

FRONT PANEL

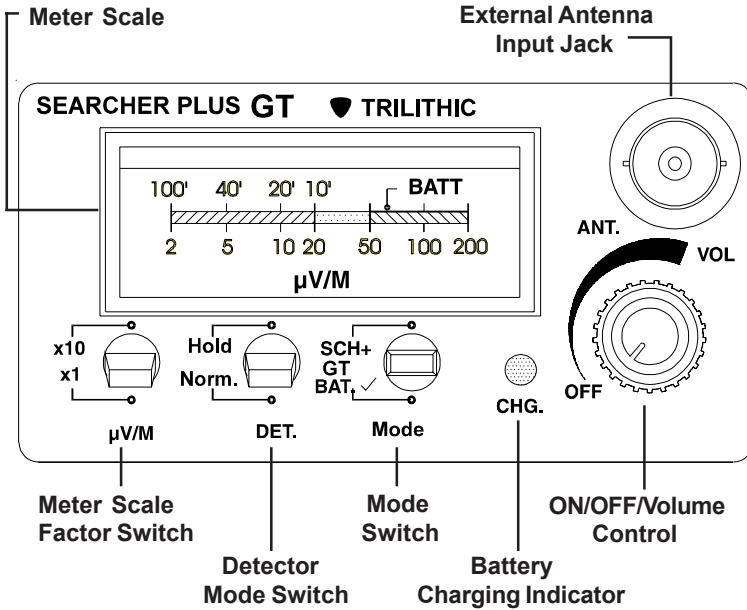

The front panel contains the following:

- External Antenna Input Jack
- ON/OFF Switch/Volume Control
- Battery Charging Indicator
- Battery Check/GT/Sch+ Switch
- Detector Mode Switch
- Meter Scale Factor Switch
- Meter Scale

EXTERNAL ANTENNA INPUT jack – a female BNC connector. Use it to attach a rubber duck antenna or a calibrated dipole (AFS-2) antenna to your Searcher Plus GT. This has a 50 Ohm input impedance.

ON/OFF SWITCH/VOLUME CONTROL knob – used to switch your Unit's action. OFF is set at the full *counter-clockwise* position. A *clockwise* rotation of the knob INCREASES the Leakage Receiver's volume.

BATTERY CHARGING indicator – a RED LED. When it is lit, it indicates that the battery is being charged.

BATTERY CHECK/GT/SCH+ MODE switch – multifunction control.

1. In the **BATTERY CHECK** position, the Meter indicates the status of the battery. This position is accessed by pressing down on the switch. When released, the switch returns to the center, GT, position.

Accurate level readings are obtained **ONLY** when the needle falls to the **RIGHT** of the **BATT.** mark during the battery check. If the needle is the **LEFT** of the mark, the battery needs charging. Even if the Unit seems to operate properly, the accuracy of the level readings may be off.

2. Use the **GT** position to enable the meter's resistance to "false alarms" from noise and overbuilt systems.
3. Use the **SCH+** setting to disable the GT feature.

DETECTOR MODE switch – determines how the meter indication changes as field strength changes.

1. When the switch is in the **NORMAL** position, your Searcher Plus GT moves **UP** and **DOWN** as the field strength shifts.
2. If the Unit is in the **HOLD** position, the Unit holds at the maximum field strength it encountered in the last 5 seconds. If the field strength drops, the Meter holds for 5 seconds before dropping.

METER SCALE FACTOR switch – used to determine the value of the field measurement taken by your Leakage Receiver.

1. When the switch is in the **x1** position, the measured field strength is shown on the meter face (2 to 200 μ V/m).

2. If the switch is in the x10 position, the measured field strength is TEN TIMES the level shown on the meter face (20 to 2000 $\mu\text{V}/\text{m}$).

METER SCALE – used in three different ways.

1. **With Dipole** – when the Unit is used with an AFS-2 calibrated dipole antenna, the **METER SCALE** indicates field strength in $\mu\text{V}/\text{m}$.

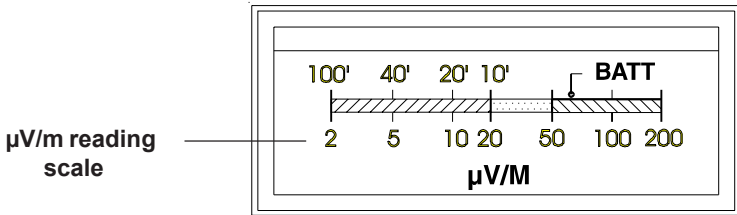

2. **Leak exceeds FCC limits** – use the upper markings to determine if a leak from a known source exceeds the FCC's limits (specified at 20 $\mu\text{V}/\text{m}$ measured 10 feet from the source).

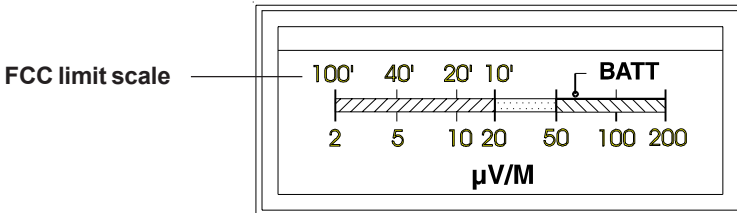

As the distance from the source *increases*, the leakage limit *decreases*. The top scale (FCC limit scale), indicates the maximum distance you can be from the source of a leak for the measured field strength to be within FCC limits.

Example: The Meter indicates a field strength of 5 $\mu\text{V}/\text{m}$. If you were not within 40 feet of the leak when you took the reading, the leak will most likely exceed the FCC limit of 20 $\mu\text{V}/\text{m}$ when measured 10 feet the source.

3. **Battery Charge Status** – you can check the charge status of the internal NiCad battery when the Meter is in the BATTERY CHECK Mode.

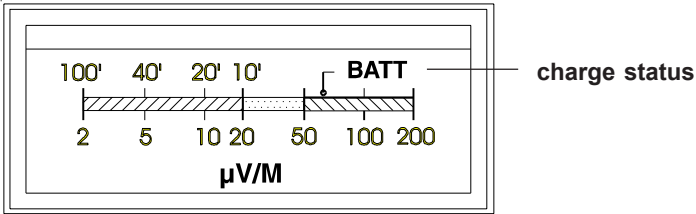

REAR PANEL

The rear panel contains the following:

- Vehicle Antenna Input
- Squelch Control

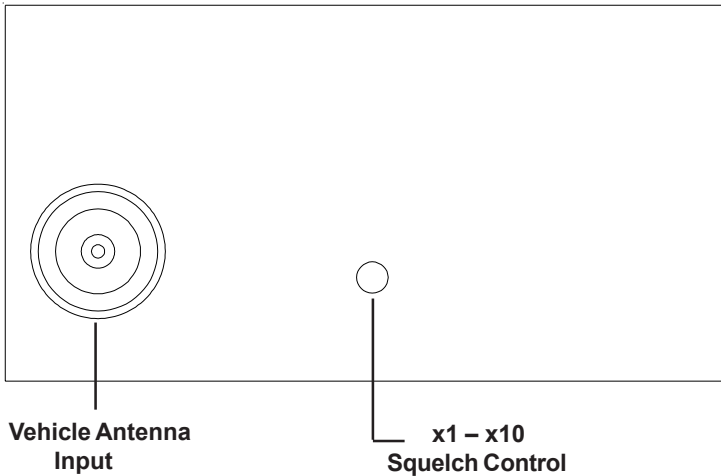

VEHICLE ANTENNA INPUT – supplies connections to a vehicle's power source and whip antenna when your Searcher Plus GT is installed in a mobile mount. This connection is made via a DC Power Inserter which is provided with your Unit.

CAUTION: Only the vehicle mounted whip antenna should be attached to the **VEHICLE ANTENNA INPUT**. Any other type of antenna (i.e. rubber duck or dipole) should be attached to the **EXTERNAL ANTENNA INPUT** jack on the front of the Meter.

When you install your Unit in the vehicle mounting bracket, the **EXTERNAL ANTENNA INPUT** jack is disconnected. The vehicle whip antenna is connected as well as vehicle power which is used to run the Unit. While the unit is in the mounting bracket, the vehicle's power supply will charge your Sercher Plus GT's NiCad battery.

x1 – x10 SQUELCH CONTROL – used to control the signal strength required to break squelch in the x1 – x10 ranges.

Your Searcher Plus GT is factory set at $2\mu\text{V}/\text{m}$ for use with an AFS-2 type antenna.

The setting can be adjusted anywhere in the range of 2 to $20\mu\text{V}/\text{m}$.

Power Source

Now that you are familiar with your Meter's controls, let's take a look at its power source.

BATTERY

The Searcher Plus GT uses a 8.4 Volt NiMh battery which has a life of 4 hours with a 10% audio duty cycle. You can check the status of the battery level with the **BATTERY CHECK/GT/SCH+ MODE** switch (see *BATTERY CHECK/GT/SCH+* page 9).

Your Meter's battery is charged from your vehicle while it is in the mobile mount.

NOTE: A full charge requires 14 to 16 hours.

MOBILE MOUNT INSTALLATION

Your Searcher Plus GT has a unique mobile adapter which connects a vehicle's charging current and externally mounted antenna to the Meter's rear panel. This enables you to maintain a charge on your Unit's NiMh battery while you are monitoring leaks.

Location

The Searcher Plus GT may be installed in any vehicle which has a +12V *negative* grounding electrical system.

1. Choose a spot in the vehicle where your Unit's front panel can be viewed easily.

CAUTION: The front panel should NOT be in direct sunlight.

Suitable locations include:

- The underside of the dash
- The top of the transmission hump
- The engine cowling in a van

WARNING: NEVER install the mobile mount overhead or in any location where the Meter could cause injury if it is dislodged in an accident.

Electrical Connection

The mobile mount for the Searcher Plus GT is equipped with a power inserter. This device combines 12 Volts from the vehicle's battery with the signal from the vehicle's mounted vertical antenna.

Route the coax and DC input cables to a suitable location (i.e. under the dash console).

Fasten the power inserter's body securely; using the clamp which has been provided.

Connect the RED (+) and BLACK (–) power leads to the electrical system ahead of the ignition switch. This ensures that 12V will be applied to the power inserter when the vehicle's ignition is OFF. This connection is necessary to charge the Searcher Plus GT overnight and to avoid an accidental discharge of the Meter's internal battery if it is left ON when the vehicle is not running.

NOTE: The Meter will NOT drain the vehicle's battery even if it is left ON overnight.

CAUTION: The Searcher Plus GT is NOT protected against reverse polarity. Make sure that the power inserter is installed correctly BEFORE placing the Unit in the mobile mount.

Vehicle Antenna

Your Searcher Plus GT is designed to work with a magnet mount 1/4 vertical antenna (model AVM or a permanent mount APM). The antenna should come trimmed to length.

Locate the antenna in the center of the vehicle's roof as far away as possible from any obstructions or other antennas.

NOTE: If antennas are in close proximity, the unit may overload and trigger when you transmit with a mobile radio or cellular telephone.

If possible, move the antennas apart to eliminate this problem. Don't worry, however, if it is not possible to move the antennas. This condition will not harm your Searcher Plus GT.

NOTE: Be sure to route the antenna's coax so that it won't be pinched or damaged.



APPLICATION

Introduction

Now that you are more familiar with your Searcher Plus GT, it's time for you to start giving it a real work out!

Your Meter was designed to extend the overall testing capacity which was first introduced with Trilithic's original SEARCHER PLUS Leakage Receiver.

The Searcher Plus GT is the first leakage measurement receiver built specifically for systems employing digital set top terminals that cannot tolerate "tagged" leakage carriers. The unit provides enhanced "false alarm" resistance and many of the features of Trilithic's **Super Plus**; without the use of a tagged leakage test signal. New circuitry in the Searcher Plus GT analyzes detected RF energy which automatically rejects all noise and signals that are not caused by leaks from your system.

Your Meter has several applications:

- Leakage Monitoring
- Localizing on the Source
- Leakage Measurement

To accomplish the above tasks, you need to understand both the measurement you wish to make and the capabilities of your unit.

Leakage Monitoring

Your Searcher Plus GT is an ideal instrument to use for daily leakage monitoring activities. To monitor leakage, you should use the following:

- Searcher Plus GT
- AVM-2/AVM-3 or APM-2/APM-3 mobile antennas
- Rubber Duck antenna when you are outside of your vehicle

MOBILE PATROL

If you are monitoring from your vehicle, make sure that your mobile antenna is installed on the roof, centered and clear of all obstacles. The coax from the antenna should be routed into the vehicle and connected to the power inserter in the mobile mount assembly.

When your Meter is secured in the mobile mount, it automatically sources RF and charge current through the back panel BNC connector.

You are now ready to start patrolling.

Relative vs. Absolute Readings

Ideally, it would be great if you could deduce the absolute value of a leak as referenced to a standard dipole at 3 meters. Unfortunately, while this ideal measurement acquisition is theoretically possible, there are a number of variables which can degrade the measurement accuracy.

VARIABLE EFFECTS

Vehicle Antenna Pickup Pattern

The AVM-2 and AVM-3 vertical antennas tend to exhibit maximum gain at low angles with respect to the ground plane. This characteristic lends itself to good performance at medium to long range. However, the performance degrades at close range because the sensitivity of the antenna lessens as it comes closer to the leakage source.

Pattern Disruption

The placement of the antenna near other antennas, booms, ladders, etc. will effect overall pickup characteristics.

Polarization Angle

Gain characteristics versus the polarization angle may have different effects and is antenna dependent.

Field Decay

Two forms of emissions are present when making "close-in" measurements:

- magnetic field (H-field)
- electronic field (E-field)

These fields can cause voltage induction on the receive antenna.

The H-field decays in a non-linear manner and generally will have some effect on "close-in" measurements (depending on frequency).

The E-field can be the primary source of antenna stimulation at 100 feet. This can result in poor correlation between ranged and actual readings.

Other Variables

Other variables which can affect your readings include obstructions, multi-leak phasing, standing waves, etc.

VARIABLE PROBLEMS SOLUTION

The most logical solution to these problems is to perform a *full* evaluation of the mobile receiver's pick-up characteristics.

This procedure should be performed off a leak of known amplitude which has been qualified by a standard measurement test (Searcher Plus GT, dipole 3 meters from leak in horizontal plane).

You also need to evaluate your vehicle in both the frontal and broadside modes at varying ranges until you are comfortable with the measurement characteristics. You can use this as a calibration source for all of your vehicles.

Relative Measurements

Now that you are aware of the difficulties in obtaining absolute measurements, let's look at the method for obtaining relative measurements. Even though you should always be cautious with measurements made at ranges other than 3 meters, it can be of great value to you to have a relative idea of the strength of the leakage signal. Since ranged measurements possess the greatest error potential, you need to have an understanding of how to correct the readings when the distances are greater than 3 meters.

To get a rough idea of the measurement value, estimate the distance to a suspect source in feet (Distance = Dft).

If the measurement is taken from a vehicle, use the distance when a peak value is indicated by the receiver. Always estimate the distance long to the nearest decade.

Divide this number by ten (10ft). Multiply the result by the meter reading (reading = MR). Thus, your formula for computing the approximate value of leakage is:

$$\frac{\text{Dft}}{10\text{ft}} \times \text{MR} = \text{approximate value of Leakage}$$

For example:

The measurement range estimate is 200 feet and the meter reading indication is 5 μ V/m.

$$\frac{200\text{ft}}{10\text{ft}} \times 5\mu\text{V/m} = 100\mu\text{V/m}$$

Your approximate value of leakage is 100 μ V/m at 10 feet from the leakage source.

Refer to the figure below for another example.

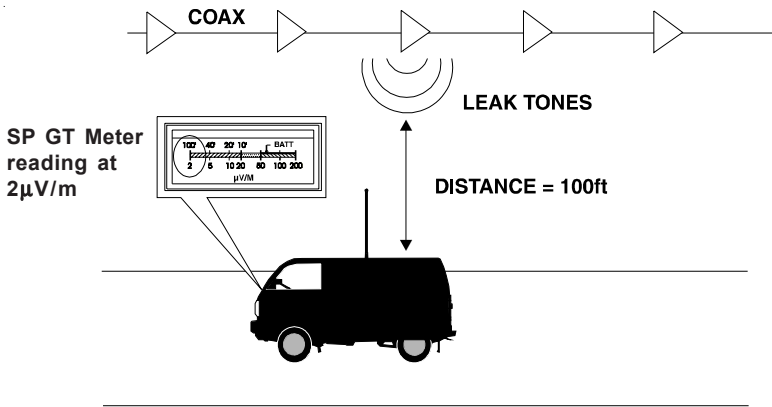

You are patrolling your area and your Searcher Plus GT is triggered by a leak. You look at your Meter and it gives you a reading of $2\mu\text{V}/\text{m}$. Let's say that you are approximately 100 feet from the source of the leak. Use your equation to figure your approximate leakage value.

$$\frac{100\text{ft}}{10\text{ft}} \times 2\mu\text{V}/\text{m} = 20\mu\text{V}/\text{m}$$

Your approximate leakage value is $20\mu\text{V}/\text{m}$ (which is the FCC limit in the Searcher Plus GT's frequency range).

You can also decrease the sensitivity when measuring large leaks by using the x10 range. Use this feature to eliminate small leaks when you are searching for the source of a large leak.

When you are in x10, your Meter breaks squelch in the $20\mu\text{V}/\text{m}$ area.

NOTE: In order to read your Meter's range scale when it is in the x10 setting, you need to multiply the $\mu\text{V}/\text{m}$ reading scale by 10. For example, 2 becomes 20, 5 becomes 50 and so on.

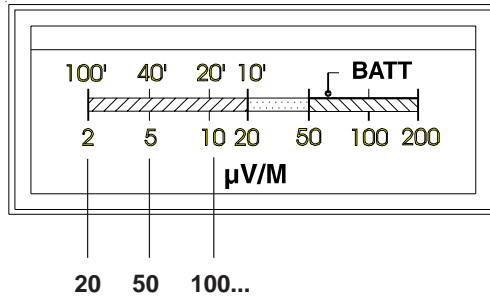

When you are in x1 (standard setting), your Meter will break squelch at $2\mu\text{V}/\text{m}$. Using the range formula, you can calculate that the maximum patrolling distance in this range setting is 100 feet. This enables you to secure readings in the $20\mu\text{V}/\text{m}$ area.

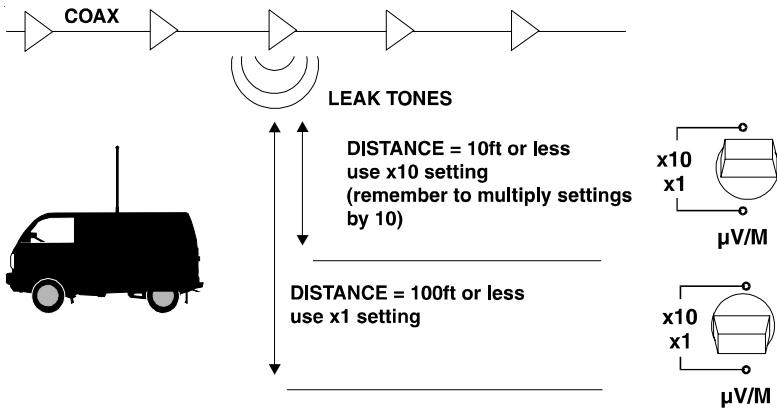

When you are patrolling, use the following rule of thumb to set your Searcher Plus GT:

10 feet or less, use the x10 setting for a maximum sensitivity of $20\mu\text{V}/\text{m}$ (don't forget to multiply the readings by 10).

100 feet or less, use the x1 or standard setting for a maximum sensitivity of $2\mu\text{V}/\text{m}$.

Localizing the Source

Your Searcher Plus GT emits an audible tone which is ideal for finding the exact source of leakage. You will need the following:

- Searcher Plus GT
- Rubber duck antenna
- Near field probe

Let's say that you are patrolling in your vehicle and your Searcher Plus GT breaks squelch. Aha! A leak! Now that you have been alerted, you need to confirm that the meter is in GT mode.

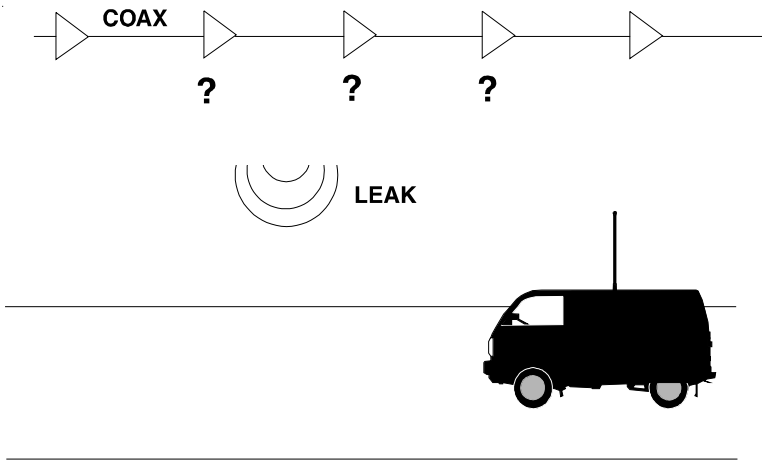

Once you have been alerted about a leak, take your Searcher Plus GT out of the mobile mount. The Unit switches electrically from the rear to the front. Attach the rubber duck antenna and keep the meter in GT Mode.

NOTE: Your meter is not as sensitive with the smaller antenna as it is with the vehicle antenna.

As your unit picks up signals, the audio VCO turns on. As you get closer to the source of the leak, the audible pitch increases.

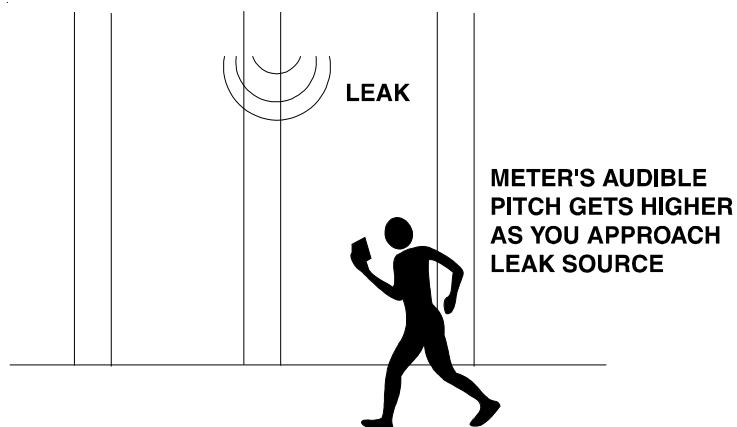

Use this audible tone to pinpoint which pole has the leak.

Unfortunately, the rubber duck antenna is not sensitive enough to locate the EXACT source of the leak. Once you have the right pole spotted, remove the rubber duck antenna and replace it with the near field probe so that you can check the targeted pole closely.

This probe is very directive off of its tip. Due to this, you must be very close to the leak for the Searcher Plus GT to respond. Use the near field probe to examine the individual connectors for shield integrity.

NOTE: When you are patrolling on foot, it is easier to pinpoint leaks by listening to the audible pitch signal than by reading the meter scale.

Leakage Measurement

Now that you have located the source of the leak, you need to measure the leak. You will need the following equipment:

- Searcher Plus GT
- AFS-2 (horizontal dipole antenna)

To measure the intensity of the leakage field, position your AFS-2 dipole antenna at a distance of 3 meters below the suspected leak and 3 meters above the ground. The AFS-2 dipole antenna comes with a telescoping rod which is automatically set at 3 meters when it is fully extended.

WARNING: Use EXTREME CAUTION when you are positioning the AFS-2. Do NOT contact the electrical distribution lines. Contact with these lines can cause SEVERE injury or DEATH!

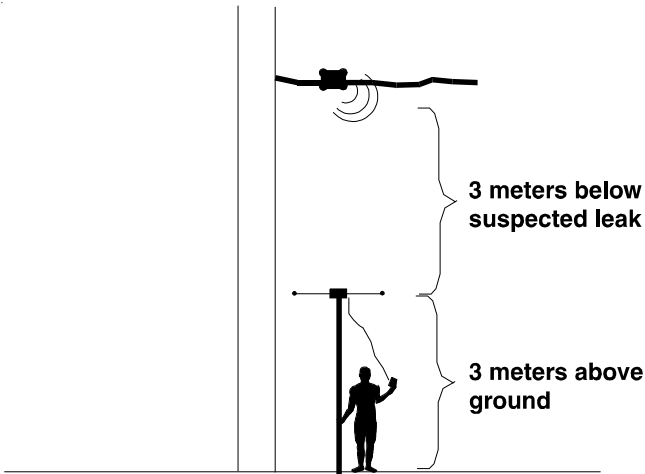

If spacing does not permit the measurement directly under the suspected component, move away from the leak until the measurement envelope is satisfied (3 meters above ground and 3 meters from the leak).

CAUTION: Do NOT have anything near the antenna such as your vehicle. You can get echoes from an obstruction. To secure the best reading, make sure that obstructions are at least 20 or 30 feet away.

Once your antenna is positioned properly, rotate it around its vertical axis and record the peak level reading. Use the peak hold feature of your Searcher Plus GT to capture this level.

Levels in excess of $200\mu\text{V}/\text{m}$ require actuation of the x10 attenuator (this changes the scale from 2 to 200 to 20 to $2000\mu\text{V}/\text{m}$). Use the audible tone to determine the peak level of leakage.

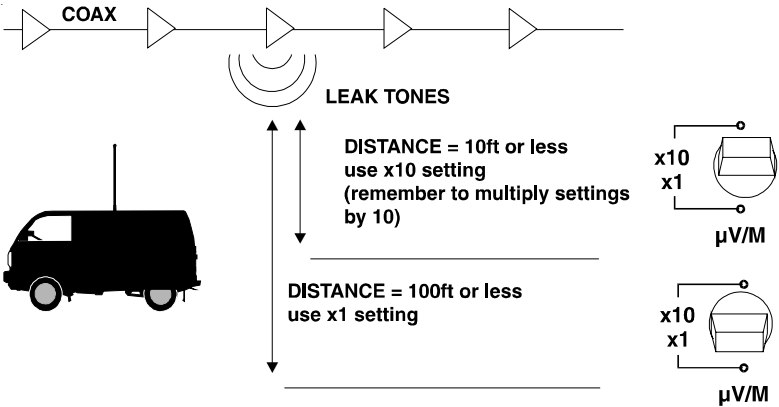

Operational Tips

Okay. You are now fairly familiar with your Searcher Plus GT. In addition to the basic procedures we have covered, there are several operational tips which you need to know to make your job easier. These include:

- Operation with CW or FM Carriers
- Setting Squelch

USE WITH CW OR FM CARRIERS

Your Searcher Plus GT is compensated specifically to detect video carriers. However, it can also be used with a CW pilot or narrow band FM leakage transmitter (such as the FDM-5); provided that the level of the carrier is lowered slightly.

To use the meter with a CW pilot or FDM-5, set the carrier level 1.5dB lower than the appropriate video carrier for that frequency.

NOTE: If you are using a leakage transmitter with a level stepping function, disable it.

ADJUST SQUELCH

Your Meter's x1 –x10 squelch level has been set at the factory for 2 μ V/m. You can change this setting by adjusting the SQUELCH control on the rear panel.

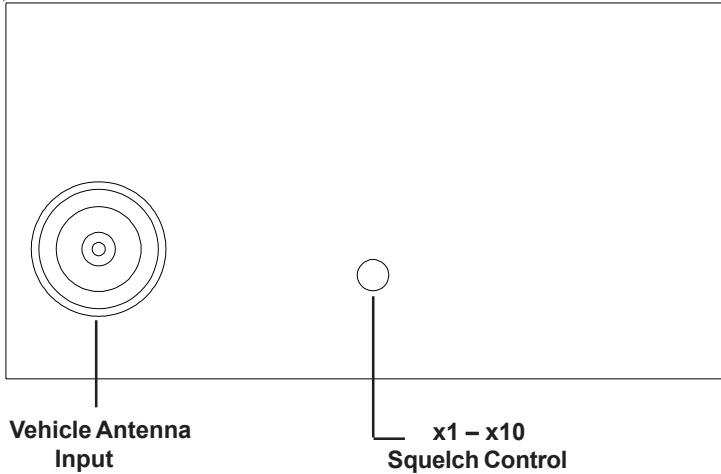

To adjust the squelch setting, refer to *CALIBRATION* page 27 or follow the steps below:

1. Find or create a leak equal to the desired squelch level. You can use your Searcher Plus GT to place the vehicle properly near a leak.
2. Remove your meter from the mobile mount. Connect the vehicle's antenna to the meter's **RF INPUT JACK** on the front panel.

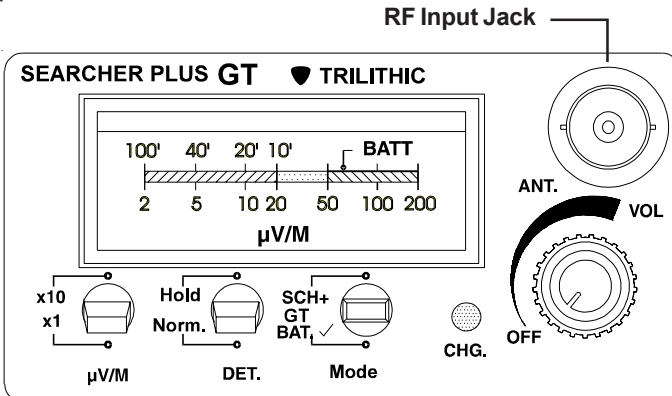

3. Put your Searcher Plus GT in the SCH+ Mode.
4. Carefully adjust the **x1 - x10 SQUELCH** control fully *counter-clockwise*. Then adjust it *clockwise* until the audio squelches OFF.

Turn the **x1 -x10 SQUELCH** control *counter-clockwise* until the audio returns.

5. Check the setting by moving toward and away from the signal source.

NOTE: The squelch circuit in the Searcher Plus GT turns OFF the meter as well as the audio. The meter will stay at the low end stop until the squelch level is exceeded.

CALIBRATION

Introduction

Trilithic recommends that you check your Searcher Plus GT for calibration accuracy on a regular basis. You may need to re-calibrate your meter occasionally.

We recommend that you establish a 20 μ V/m calibration signal (see *CALIBRATION PROCEDURE* below) and perform a quick verification test at least once a month. A complete calibration test should be performed at least once per year or more frequently if it is indicated by the monthly checks.

Calibration Procedure

The performance of your Searcher Plus GT can be verified by using the following procedure with the signals normally available at a CATV test point.

IMPORTANT: When performing the tests, make sure that the system and test cables are RF tight. The presence of leaks in the test area can cause significant measurement errors since they effectively bypass the attenuators in the test setup. Check the test area carefully with a Searcher Plus GT and rubber duck antenna before you proceed with the test.

TEST EQUIPMENT

You will need the following equipment to perform the calibration procedure:

- Signal Level Meter SP-700A, SP-1700, or Tricorder
- 75 Ohm Variable Attenuator 1 to 64dB; SA-70
- 75 Ohm Fixed Pad 20dB; FP-75/20 F
- 75 to 50 Match Network ZM-57 Matching Pad
 Female F to Male BNC ZMT-57 Matching Transformer
- Adjustable DC Power Supply 7 - 12 VDC @ 50mA
- Digital Voltmeter

TEST SETUP

Consult the Table 1 below to determine the signal level required at the input to the matching pad.

Table 1. Test Signal Levels for 200 μ V/m.

FREQUENCY	ZM-57 (5.7dB loss)	ZMT-57 (.2dB loss)
109	-15.5dBmV	-21.0dBmV
115	-16.0	-21.5
121	-16.4	-21.9
127	-16.8	-22.3
133	-17.2	-22.7
139	-17.6	-23.1
145	-18.0	-23.5
151	-18.4	-23.9
157	-18.8	-24.3

NOTE: These values include the antenna factor of a standard dipole. For a derivation of these levels, see *TEST SIGNAL LEVELS*, page 36.

TEST SETUP HOOKUP

When checking calibration of the Searcher Plus GT, the unit should be placed in the horizontal position on the bench. This will eliminate slight balancing errors near the scale edges which occur when the unit is changed from the horizontal to the vertical position. This should not effect readings near center scale. If desired, the Searcher Plus GT can be calibrated for reading while held in the vertical position. Just be sure that the technicians who use the Searcher Plus GT know which way the meter has been calibrated.

Use the figure below to make the connections for your test set hook up.

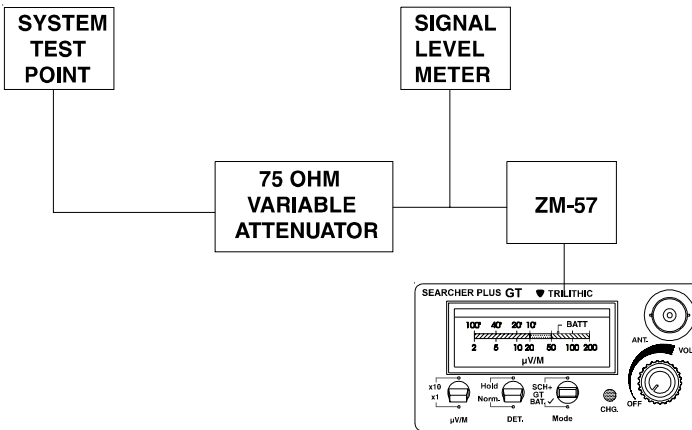

Connect the attenuator to the system test point.

Connect the signal level meter to the attenuator's output.

Then set the attenuator to get the 200 μ V/m reading as shown in Table 1 on page 28.

NOTE: If the correct level cannot be obtained with the attenuator, it may be necessary to adjust the modulator output level or add a length of coax to get as close as possible to the level listed in the table.

Make sure that you use the table for the type of matching pad you are using (i.e. ZM-57, ZMT-57).

Once the attenuator is set, note the setting needed to obtain the $200\mu\text{V}/\text{m}$ test level.

Disconnect the SLM and connect the matching pad.

CALIBRATION CHECK

Remove the Searcher Plus GT from the mobile mount.

Make sure that the battery is charged. Turn your Meter ON and depress the **BAT CHECK** switch.

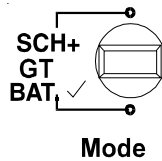

Connect the matching pad to the **RF INPUT JACK**.

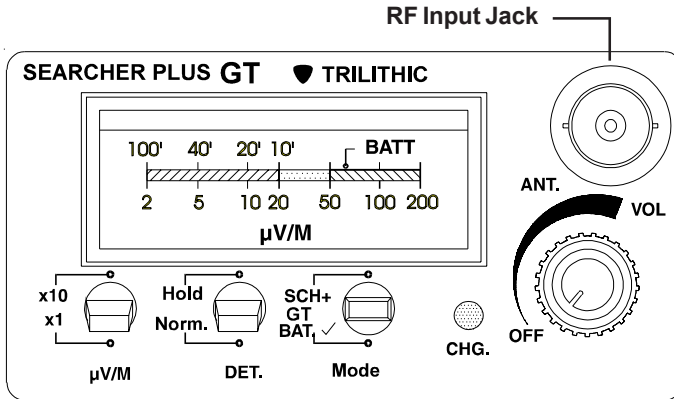

NOTE: All of the readings below have a tolerance of $\pm 1.5\text{dB}$.

1. Set your Meter to **x1** and **SCH+**. Then turn it ON and make sure that it reads $200\mu\text{V}/\text{m}$.

REMINDER: View the meter by looking straight at the dial with your eye at midscale. Do NOT follow the curve of the meter dial.

2. Check the 100 μ V/m reading by adding 6dB to the 200 μ V/m attenuator setting.
3. Check the 50 μ V/m reading by adding 12dB to the 200 μ V/m attenuator setting.
4. Check the 20 μ V/m reading by adding 20dB to the 200 μ V/m attenuator setting.
5. Check the 10 μ V/m reading by adding 26dB to the 200 μ V/m attenuator setting.
6. Check the 5 μ V/m reading by adding 32dB to the 200 μ V/m attenuator setting.
7. Check the 2 μ V/m reading by adding 40dB to the 200 μ V/m attenuator setting.

NOTE: If the unit reads substantially HIGH on the low end of the scale, it may indicate that the signal is leaking around the attenuator and that the leakage in the test area is too great to make accurate readings. Find and repair the leak or move to a quieter location before you attempt to calibrate your Searcher Plus GT.

PROCEDURE

If your calibration check indicates that your Searcher Plus GT needs calibration, perform the following procedure.

1. Remove the top cover as shown below.

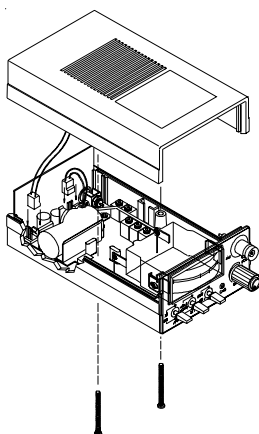

2. Set up a $200\mu\text{V/m}$ signal level as described in *TEST SETUP HOOK UP* on page 29.
3. Set your unit to **x1** and **SCH+**. Turn the **x1 - x10 SQUELCH** control on the rear panel fully *counter-clockwise*. Connect the signal to the **RF INPUT JACK** on the front panel.
4. Set the meter for $200\mu\text{V/m}$ using the R28 MTR GAIN.

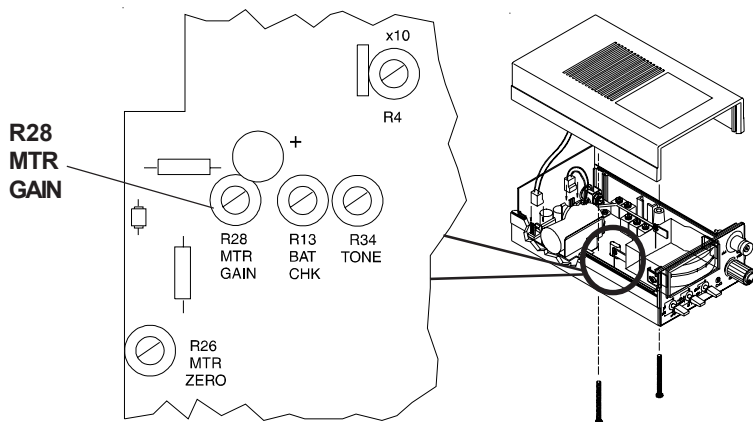

5. Add 40dB to the attenuator setting. Then, set the meter for $2\mu\text{V/m}$ using R26 MTR ZERO.

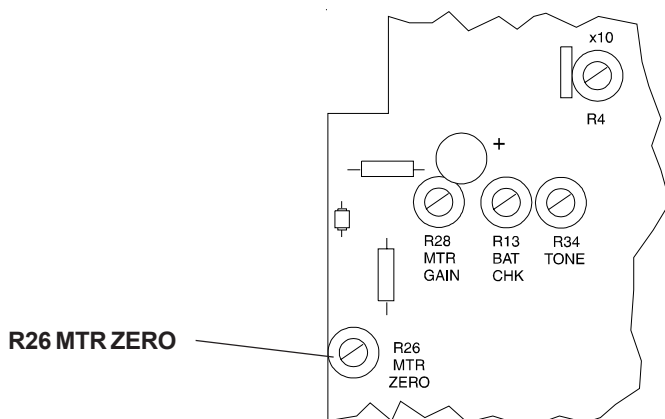

6. Check the rest of the calibration points. See *CALIBRATION CHECK* page 30.

- Readjust R26 and R28 as necessary for best tracking over the scale.

Units are calibrated at the factory to average the errors over the entire scale. If you desire, your meter may be calibrated for best accuracy in the center of the scale only; thus resulting in greater error at the scale extremes.

ATTENUATOR x10

You can also adjust the x10 attenuator.

- Add 20dB to the 200 μ V/m attenuator setting. This will set the test signal to the 20 μ V/m level.
- Note your meter's reading.
- Reset the test signal level to the 200 μ V/m value.
- Depress the **x10** switch.

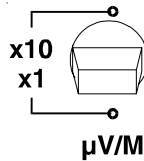

- Adjust R4 to get the same reading as noted with the 20 μ V/m test level in Step 2 above.

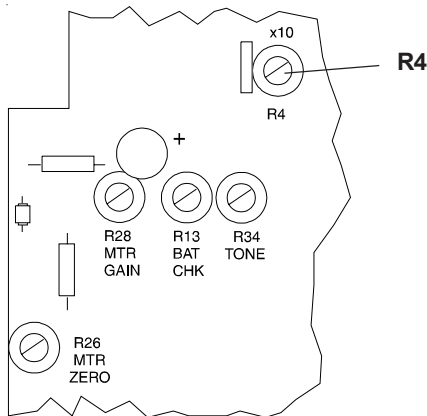

SET SQUELCH

Now, set the x1 - x10 squelch.

1. Set the test level to $2\mu\text{V/m}$.
2. Set the Unit to x1 range and SCH+ Mode.
3. Adjust the x1 - x10 squelch, **R37**, so that the unit just breaks squelch.

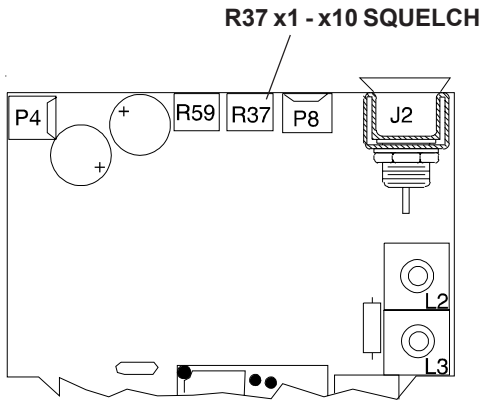

4. Reduce the test signal by 1dB and fine tune the setting of **R37** so that the meter is squelched OFF.
5. Repeat the procedure until you achieve the desired results.

BATTERY CHECK

Now is a good time to check your battery.

1. Remove the battery. Lift on the back end of the battery and pull it up and out of the holder.

2. Apply 7.55 VDC to the battery socket. Connect the *negative* supply lead to the bracket holding J2 and the *positive* supply lead to the battery socket terminal nearest R4.

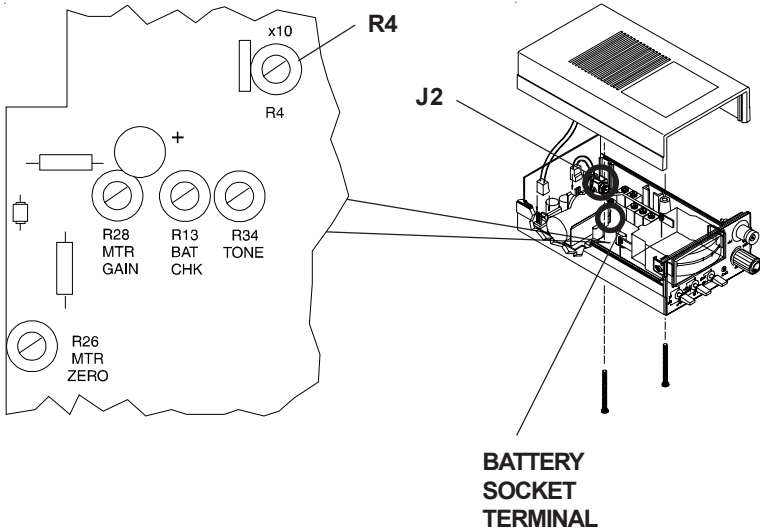

3. Depress the **BAT CHK** switch.

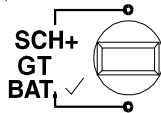

Mode

4. Adjust R13 for a meter reading of the BATT line.

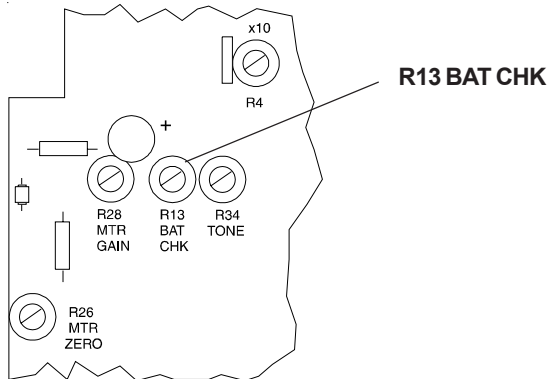

5. Reinstall the battery into your meter.

TEST SIGNAL LEVELS

The test signal levels for calibrating a Searcher Plus GT are based on the standard equations below.

$$\text{Level (dBmV)} = 20 \log \left(\frac{E (\mu \text{ V/m})}{20.5 \times F (\text{MHz})} \right)$$

Where:

E (μ V/m) = desired level

F = Frequency in MHz

Example #1

20 μ V/m is desired level

133.2625 (MHz)

$$\begin{aligned} \text{Level (dBmV)} &= 20 \log \frac{20}{20.5 \times 133.2625} \\ &= 20 \log \left(\frac{20}{2731.8813} \right) \\ &= 20 \log (0.007321) \\ &= -42.7086 \approx -42.71 \text{ dBmV} \end{aligned}$$

Example #2

200 μ V/m is desired level

133.2625 (MHz)

$$\begin{aligned} \text{Level (dBmV)} &= 20 \log \frac{200}{20.5 \times 133.2625} \\ &= 20 \log \left(\frac{200}{2731.8813} \right) \\ &= 20 \log (0.0732096) \\ &= -22.7086 \approx -22.71 \text{ dBmV} \end{aligned}$$

ADDITIONAL INFORMATION



Specifications

The specifications for your Searcher Plus GT are as follows:

Frequency Range	Single Channel Frequency, 108 to 157.25 MHz
Selectivity	Typical 6 kHz at -3dB
Input Sensitivity	2 uV/m in x 1 mode 20 uV/m in x 10 mode
Squelch	Front panel selectable to break on GT mode (video + level) or Searcher Plus mode (level only)
Measurement Accuracy	± 1.5 dB @ 25°C (77°F) ± 3.0 dB @ -18°C (77°F) to 49°C (0° to 120°F)
Alarm Indication	Audio Tone with pitch propor- tional to meter deflection
Meter Functions	2 - 2000 uV/m, normal amplitude tracking. When detector is set to HOLD mode, the peak reading is held 5 seconds before auto-reset.
Power	Rechargeable NiMh battery, internal charger operates from 13.8 VDC vehicle power.
Weight	1 lb. (0.45kg) without mobile mount.
Dimensions	1.75" H x 3.5" W x 5.25" D (44mm x 89mm x 33mm)



TRILITHIC
INNOVATIVE ENGINEERING

9710 Park Davis Drive
Indianapolis, IN 46236