



MODEL ONE

OPERATION MANUAL



TRILITHIC

The Best Thing on Cable



TRILITHIC, Inc. is a leading supplier of test equipment to the broadband industry, specializing in products and systems that make HFC system maintenance simpler, faster and more precise. Innovations include the first practical CATV sweep system (1976), the first CATV return adjustment system (1981), the SEARCHER PLUS for leakage measurement (1989) and the first integrated return path quality management system (1995).

TRILITHIC is very well known for its leakage products, and more than 15,000 SEARCHER PLUS Leakage Receivers are now in daily use. The SUPER PLUS / CT-2 leak detection system carried leakage measurement into the current era of overbuilds and digital services.

TRILITHIC has long been a leading supplier of signal level meters. The ground breaking TRICORDER, the first small, multifunction SLM with leakage measurement and data logging, has recently been joined by the Model One, which sets new standards for compactness, cost-effectiveness and functionality.

TRILITHIC is a major force in return path quality assurance, offering the industry's only complete return maintenance system. The Guardian line spans the full range of return testing applications, and the Guardian RSVP, the first practical reverse path tester for installers, now equips many thousands of HFC installers around the world.

In addition to products for the broadband industry, TRILITHIC produces RF and microwave components and equipment that are integrated into the aerospace and wireless communications products of other manufacturers. TRILITHIC also designs custom test and measurement subsystems, supplying computer-controlled manufacturing, signal routing and network maintenance systems that perform a wide range of communications and aerospace applications.

TRILITHIC products are designed and manufactured at our facility in Indianapolis, Indiana and in Tienjin, China, and are distributed by sales agents in over 40 countries. For more information concerning TRILITHIC products and services, please contact us at the address or telephone numbers below or visit our web site, www.trilithic.com.

TRILITHIC, Inc.
9202 East 33rd. Street
Indianapolis, IN 46235
(317) 895-3600
(800) 344-2412



TWO YEAR WARRANTY

Trilithic, Inc. warrants that each part of this product will be free from defects in materials and workmanship, under normal use, operating conditions and service for a period of two (2) years from date of delivery. Trilithic, Inc.'s obligation under this Warranty shall be limited, at Trilithic, Inc.'s sole option, to replacing the product, or to replacing or repairing any defective part, F.O.B. Indianapolis, Indiana; provided that the Buyer shall give Trilithic, Inc. written notice.

Batteries are not included or covered by this Warranty.

The remedy set forth herein shall be the only remedy available to the Buyer under this Warranty and in no event shall Trilithic, Inc. be liable for incidental or consequential damages for any alleged breach of this Warranty. This Warranty shall not apply to any part of the product which, without fault of Trilithic, Inc., has been subject to alteration, failure caused by a part not supplied by Trilithic, Inc., accident, fire or other casualty, negligence or misuse, or to any cause whatsoever other than as a result of a defect.

Except for the warranty and exclusions set forth above, and the warranties, if any, available to the Buyer from those who supply Trilithic, Inc., there are no warranties, expressed or implied (including without limitation, any implied warranties of merchantability of fitness), with respect to the condition of the product or its suitability for any use intended for it by the Buyer or by the purchaser from the Buyer.

 TRILITHIC

9202 E. 33rd Street
Indianapolis, IN 46235

INDEX**General Information**

Introduction	3
Equipment	4
Features	4
Level Measurements	5
Single Channel Display	5
Tilt and Favorite Group Display	5
Scan Display	5
Spectrum Display	6
Carrier-to-Noise (C/N)	6
Digital Channel Measurement	6
Data Logging	6
Voltmeter Function	6
Printer Feature	7

Model One Walkthrough

Introduction	9
Identify Components	9
Key Pad	10
Soft Buttons	11
Power ON/OFF	11
Arrow Buttons	11
Function Buttons	11
Navigate Through Functions	12
Display Screen Description	13
Battery Charging	14

Model One Setup

Introduction	17
Information Display	18
General Display	19
Backlight	19
LCD Contrast	19
Shutdown Time	20
Date & Time	21
Volume	22
Printer Setup	22
LCD Test	23
Measurement Display	23
Scan Audio	24
Scan Enabled	24
Transmission	25
Limit Setup	25
Freq Tuning Step	27
Signal Level Units	28
Temperature Units	28
Load Default	29
Prior Menu	29

Channel Plan Display	29
Learn Channel Plan	30
Edit Channel Plan	31
Tilt/Favorite	34
Basic Operation	
Introduction	37
Single Channel Test	38
TV Channels	39
Single Frequency Channels	41
Digital Channels	42
Frequency Mode	43
Channel Spectrum Scanning	
Measurement	44
Limit Display	47
Frequency Spectrum Scanning	
Measurement	48
Carrier-to-Noise Measurement	51
Tilt and Favorite Channel	51
Battery and Trunk Voltage	
Measurement	53
Advanced Operation	
Introduction	55
Transmission Characteristic Test	55
Saving Data	60
File Notation	62
Loading Data	64
Printing Operation	66
Serial Printer	67
Parallel Printer	68
Specifications	71

GENERAL INFORMATION

Introduction

Congratulations! You now own Trilithic's **Model One Signal Level Meter**. This instrument is designed to provide you with optimal features for reduced cost.

Amplitude measurements are fast and efficient. Carrier amplitudes are displayed singly, as a group (up to eight "favorites"), or as a full-span display. It also features a single channel SPECTRUM Mode which displays the presence of interfering beats in addition to the carrier amplitudes. The unit enables you to take the direct power measurement of QAM signals, carrier-to-noise measurements, data logging and also supports a voltmeter function.

The Model One makes it easy to obtain a hard copy of installation data or documentation of a problem via its printer function. By connecting the unit to a serial printer, you can download its display or records. If you are using a parallel printer, you can print out the records.

The unit is the ideal signal level meter for HFC installations. It is durable, has many features and is simple to use in a wide range of conditions. It's tough, plastic shell and protective jacket make the Model One highly resistant to damage from shock and impact. When not in use, the unit and its accessories are contained in a carrying case.

The Model One is rugged and convenient to use. It weighs only 1.5 lbs and can be carried and operated with one hand. All measurement functions are accessible via a single keystroke. Other functions are simplified through the combination of dedicated function keys and "softkeys".

Equipment

The Model One comes with the following:

- Model One Signal Level Meter
- Carrying Case
- Strap (for Carrying Case)
- Instrument Sleeve
- Built-in 7.2V/1.8AH Ni-MH Battery
- Universal Charger
- BNC Connector Adaptor
- Operation Manual

The following options are also available:

- Holster (P/N 2130854000)
- Software Kit (includes data cable) (P/N 2071362000)
- Data Cable (P/N 2071351000)
- Serial Printer Cable (P/N 2071352000)
- Parallel Printer Adaptor (P/N 0440202000)
- Cigarette Charger Adapter (P/N 2071350000)
- Replacement Battery (P/N 0090044000)
- Replacement Charger (P/N 0610160000)

For more information, please contact Trilithic:

www.trilithic.com; 1-800-344-2412

Features

The Model One supports a variety of functions including:

- Level Measurements
- Tilt/Favorite Group Display
- Scan Display
- Spectrum Display
- Carrier-to-Noise (C/N)
- Digital Channel Measurement
- Data Logging
- Voltmeter Function
- Printer Outputs

LEVEL MEASUREMENTS

The Model One can display a single channel, groups (up to eight) of “favorite” channels or all channel amplitudes.

The channel plans for the display can be configured either on the unit’s front panel or downloaded from a PC.

Single Channel Display

When tuned to a single channel, the Model One displays bar graphs for the video and audio carriers. It also shows numeric readouts of the carrier amplitudes and V/A difference. In addition, the unit provides a spectral display of intermodulation products or other undesired signals that may be present.

TILT AND “FAVORITE” GROUP DISPLAY

Press the **TILT** button to display a graph showing the amplitudes of up to eight user-selected video carriers. This display also shows the calculated difference in amplitude (tilt) between the HIGHEST and LOWEST channels in the user-selected group. Press **TILT** again and the Model One displays a numeric list which shows the amplitudes of the carriers in the group.

SCAN DISPLAY

Press the **SCAN** button to display the full span of video carriers. This mode is useful to make a quick check of your system’s overall flatness and amplitude.

The Model One can be set to display both audio and video carriers at reduced frequency spans. This means that you can impose amplitude limits on the display. By using the unit’s frequency marker, you can zoom in on any suspect channel that appears in the display.

SPECTRUM DISPLAY

Press the **SPECT** button to display the spectrum measurements with frequency spans from 2 MHz to 50 MHz or a full-spectrum scan.

CARRIER-TO-NOISE (C/N)

Press the **C/N** button to measure the C/N ratio of the CATV transmission system.

DIGITAL CHANNEL MEASUREMENT

The meter includes a special single-channel mode that you can use to measure the actual power of a QAM signal. The display will show the actual shape of the modulation “haystack”. This feature provides you with a powerful tool for detecting in-channel unflatness or mismatches that might affect digital transmission quality.

DATA LOGGING

The Model One has the capability to store the amplitudes of all video and audio carriers. This means that up to 24 full data records can be captured in non-volatile memory and later uploaded to your PC for record-keeping.

Each record carries the time, date, and the configuration of the meter at the time of record capture. It also enables you to annotate the record with a title name or comment.

VOLTMETER FUNCTION

This meter is equipped with a built-in voltmeter which can be used for troubleshooting power supplies or power drops.

The Model One displays the voltage as a bar graph and numeric readout. It can accommodate AC or DC voltages up to 120 Volts.

PRINTER FEATURE

In addition to being able to upload data records to a PC, the Model One can also download records or it's current display to a serial printer.

If you are using a parallel printer, the Model One can download records. This is useful to obtain an instant hard copy of your installation or to document a problem (see *Printer Operation* page 66 for more information).

MODEL ONE

WALKTHROUGH

Introduction

Now that you have your Model One out of its box, take a few moments to look it over so that you become familiar with its controls.

NOTE: Your meter's battery may need to be charged (see page 14).

Identify Components

The Model One's function buttons and backlit LCD display are on the front panel. The unit's charge socket and printer interface socket are on the bottom. The belt clip is located on the back of the unit.

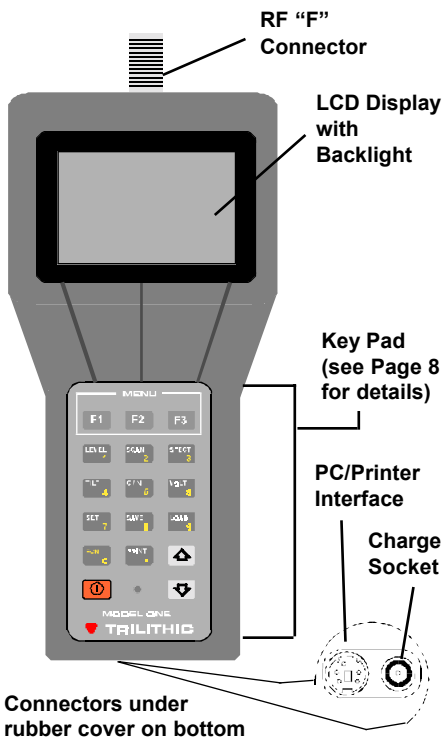

The RF “F” connector is on the top of the unit (a BNC Connector Adaptor is included in the bag).

KEY PAD

The key pad consists of the various buttons to access the Model One’s functions. There are eleven function buttons, two arrow buttons (up, down), the power on/off button and three “soft buttons” which enable you to perform functions in the display.

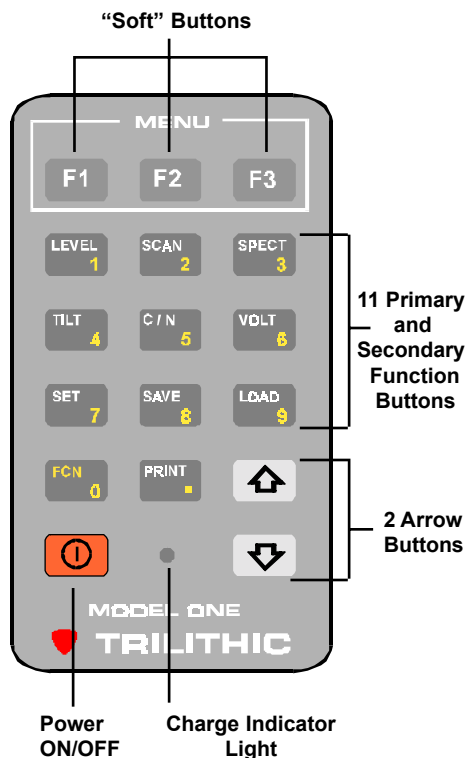

Soft Buttons

F1, **F2** and **F3** are used to access various functions within the display menus. On specific displays, three boxes appear at the bottom of the display.

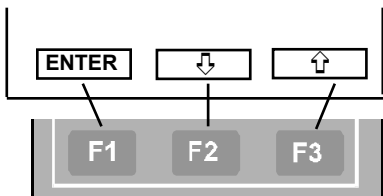

These boxes correspond to the three soft keys and provide additional commands such as ENTER, EXIT, NOTE (for making personal notations), movement arrows, etc. (See the individual function displays for more information).

Power ON/OFF

Use the **POWER ON/OFF** button to turn the meter on and off.

Arrow Buttons

The **UP** and **DOWN ARROW** buttons are used to change values (i.e. Channel Number, Frequency, etc.) within a function display.

Function Buttons

The following is a list of the function buttons:

Function	No.	Purpose
Level	1	Enter Single Channel/ Frequency Measurement
Scan	2	Enter Channel Spec- trum Scanning Mode
Spect	3	Enter Frequency Spec- trum Scanning Mode

Function	No.	Purpose
Tilt	4	Enter Tilt Measurement Mode
C/N	5	Enter Carrier-to-Noise Ratio Measurement Mode
Volt	6	Check Voltage (battery and power supply/drop)
Set	7	Set Up Display Parameters
Save	8	Enables you to save the Channel Scan display data and record or scan and save a new data record
Load	9	Enables you to open previously saved display data or data record
FCN	0	Puts the key pad into a second function (i.e. enables you to input numbers into a display)
Print	.	Print display data or data record

Navigate Through Functions

You utilize several methods to navigate through the Model One's functions.

For some procedures, use the **ARROW** buttons to make changes within a specific screen such as to increase or decrease values.

To scroll through a specific display's menu topics, use the designated "soft" buttons (usually **F2** and **F3**).

NOTE: The Model One does not support a “wrap around” feature. If you are at the bottom of a menu list and wish to go to the top, you will need to press the UP arrow indicator rather than continue pressing the DOWN arrow.

Within several displays, you will want to enter numeric values. Press the **FCN** button to put the key pad in it's secondary function mode and then press the number buttons to enter the desired value. For example, to enter the number 12:

Press **FCN** **0** + **LEVEL** **1** + **SCAN** **2**

Then press the “soft” button for ENTER (i.e **F1**) to record the value into the Model One.

If you make an error, you can press **F2** to cancel the number and then reenter it. Press **F3** to quit or exit the operation.

Display Screen Description

Each display contains the following sections or features.

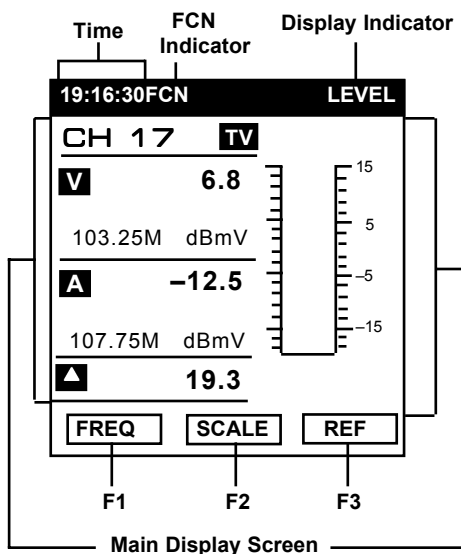

- Time – Displays unit's time based on time set up parameter (see page xx)
- FCN – Indicates when the **FCN** button has been pressed and the key pad is in its secondary function (see page 9)
- Display Indicator – Indicates which meter function is being used
- Main Display Screen – Displays the parameters and graphs of the selected function
- F1, F2, F3 – Indicates the available usage for the soft buttons in the selected meter function

NOTE: The soft buttons vary from meter function to meter function (see *Soft Buttons* page 11).

Battery Charging

The Model One has a built-in 7.2V/1.8AH Ni-MH battery. When fully charged, it can be used for over three hours.

When the voltage of the battery drops below 6.4V, the battery symbol *flashes* in the information line at the top of the display screen.

Flashing battery symbol indicates low voltage

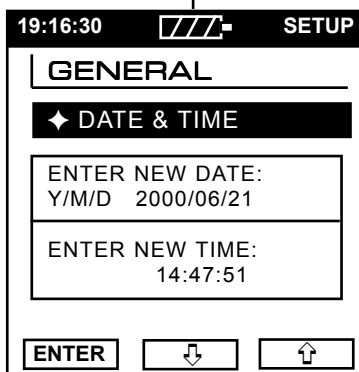

NOTE: If the voltage drops below 6.2V, the Model One shuts off automatically to protect the battery.

You will not be able to turn the meter on again until you recharge the battery.

To charge the Model One's battery, connect the charge cube to the charge socket on the bottom of the meter (see page 9) and plug the charger into an outlet.

WARNING: The Model One's battery **MUST** be charged with the Trilithic charger provided with the meter. Using any other charger may damage the battery.

Allow twelve to sixteen hours to charge the battery fully.

MODEL ONE

SETUP

Introduction

When you first press the **POWER ON/OFF** button, the Model One displays its **INFORMATION** screen briefly and then displays the last screen it was on when it was powered down.

CAUTION: Your unit's battery may need charging prior to use (see page 14).

Before using the Model One, you need to perform some set up procedures which include:

- Information (general information about your meter)
- General (date and time, contrast for the LCD display, volume, etc.)
- Measurement (signal level units, temperature units, scan audio, transmission, etc.)
- Channel Plan (set up the channel plan to use for testing)

NOTE: Model One software may be used to set up the meter. It also enables you to restrict access to the **MEASUREMENTS** and **CHANNEL PLAN** menus.

To enter the set up display, press the **SET** button.



This brings up the SETUP menu.

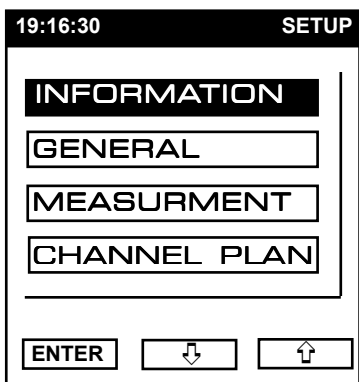

Use **F2** and **F3** arrows to scroll down the menu list of command boxes.

REMINDER: The Model One does not have a “wrap around” feature. If you are at the bottom of the menu list and wish to return to the middle or top, you will need to press the UP arrow to return to the top.

When the desired command is highlighted, press **F1** (ENTER) to select the display.

Information Display

The INFORMATION display window contains useful information regarding your Model One.

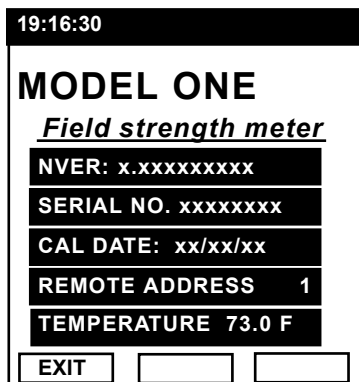

The information includes the unit's firmware version, serial number, calibration date, remote address and current internal temperature.

General Display

Use the GENERAL Display screen to set the performance parameters of your unit.

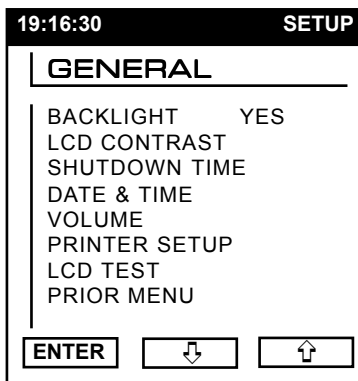

Access the specific parameters the same way you entered the display. Use **F2** and **F3** to scroll through the command choices and press **F1** to enter the field for the desired parameter.

BACKLIGHT

Press **F1** (Enter) to *toggle* between ON and OFF. If the LCD backlight is ON, the meter will indicate YES beside that parameter. If OFF, the meter will indicate NO.

LCD CONTRAST

Use **F2** or **F3** to scroll to the LCD CONTRAST parameter. Use the **UP** arrow button on the key pad to DARKEN the contrast and the **DOWN** arrow to BRIGHTEN.

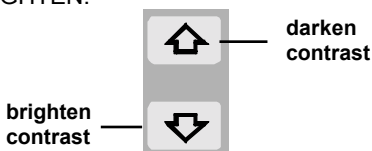

NOTE: Since the Model One memorizes the video parameter set up, be careful not to set the display contrast too low. This may cause the liquid display to be too dim or not visible at all which can affect your meter's operation.

SHUTDOWN TIME

The Model One's automatic shutdown timer can be adjusted to one of several parameters. You may set it so that it will stay on until you manually turn it off.

You can also set it so it will shut off after there has been no key pad activity for a specified time interval (3 minutes, 5 minutes, 10 minutes or 30 minutes). By setting it to one of the timer shut offs, you can save battery power during periods of inactivity.

Use **F2** or **F3** to scroll to the SHUTDOWN TIME parameter. Press **F1** to enter the SHUTDOWN screen.

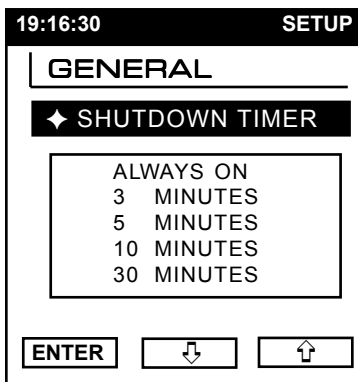

To select the desired shutdown parameter, use **F2** or **F3** to scroll to the desired time. Then press **F1**. The unit will return to the GENERAL display.

To have the unit remain on until you turn it off, select ALWAYS ON. To set the automatic shutdown function, select either 3 MINUTES, 5 MINUTES, 10 MINUTES or 30 MINUTES. If you choose any of the automatic shutdown times, the unit will turn off in the designated time if there is no key pad activity (pressing of buttons).

DATE & TIME

Use **F2** or **F3** to scroll to the DATE & TIME parameter. Press **F1** to enter the screen.

19:16:30 SETUP

GENERAL

◆ DATE & TIME

ENTER NEW DATE:
Y/M/D 2000/06/21

ENTER NEW TIME:
14:47:51

ENTER [DOWN] [UP]

Since you will be inputting data, you need to switch the meter to the numeric function. Press the **FCN** button.



You may change the order of the date (month/date/year) to any order. Use the **UP** and **DOWN** arrow keys to rearrange the order. To enter the date, use the numeric keys (1 - 0).

NOTE: There is no back key. If you make an error, use **F2** to scroll to the TIME entry and then **F3** to return to the DATE line. This will restore the date line to the previous entry.

NOTE: The Model One automatically assigns the first two digits in the year (20). When entering the year, you only need to add the last two digits.

When the DATE is entered, press **F2**. This scrolls you down to the TIME line. Enter the desired time via the numeric (**FCN**) buttons.

NOTE: The Model One is based on a 24 hour clock. For example, 3:15:49 PM should be input as 15:15:49.

Press **F1** (ENTER) to log the change and return to the GENERAL display.

VOLUME

Use **F2** or **F3** to scroll to the VOLUME parameter. Press the **UP** arrow button to INCREASE volume and the **DOWN** arrow button to DECREASE volume.

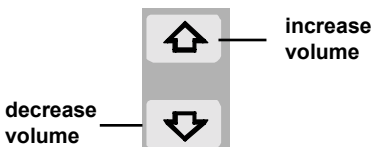

PRINTER SETUP

The Model One enables you to print both the current display screen or a specific report. See *PRINTER OPERATION* page 66 for more information.

Scroll to the PRINTER SETUP command and press **F1**.

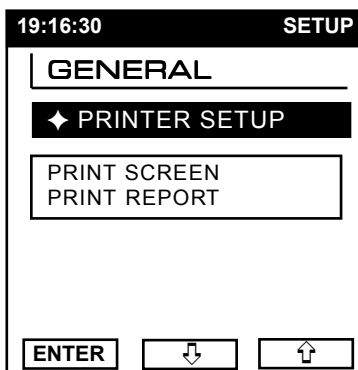

You may print either the current display or a report. Use **F2** or **F3** to select the desired printing job.

LCD TEST

Scroll to LCD TEST and press **F1**. The meter will execute several patterns to test each of the LCD's display points. The patterns should appear as all white, all black, vertical stripe and then checkerboard.

NOTE: If the temperature is below 0°C, the display speed of the LCD will slow down.

Once the parameters have been set to your specifications, scroll to PRIOR MENU and press **F1**. This returns you to the SET UP display.

Measurement Display

Once your meter's parameters have been established and you are back to the main set up menu, use **F2** or **F3** to scroll to the MEASUREMENT command box.

Press **F1** to enter the MEASUREMENT display so that you can set up the meter's measurement parameters.

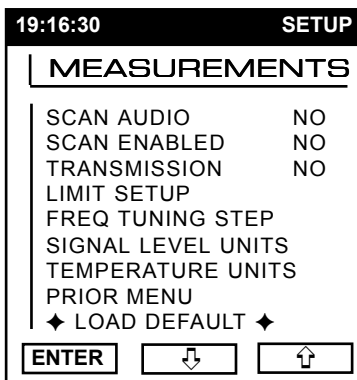

SCAN AUDIO

Use **F2** or **F3** to scroll to SCAN AUDIO. Use **F1** to *toggle* this parameter between ON and OFF (YES or NO).

Select YES if you want the meter to graph Audio and Video carriers with the CHANNEL SCAN function.

If you select NO, only the Video carriers will be graphed. However, both Audio and Video levels will be shown on the display and printed reports.

NOTE: When SCAN AUDIO is selected (YES), only a maximum of 50 channels are viewable on the display at one time. Use the **UP** and **DOWN** arrow buttons on the key pad to change the displayed frequency spectrum in order to see additional channels.

SCAN ENABLED

When the SCAN ENABLED function is selected, the Model One scans only the active channels in the Channel Plan. This provides the most efficient access to your CATV system information.

Use **F2** or **F3** to scroll to SCAN ENABLED. Use **F1** to *toggle* this parameter between ON and OFF (YES or NO).

TRANSMISSION

Scroll to TRANSMISSION and press **F1** to *toggle* the parameter between enabled and disabled (YES or NO). Use this parameter to test for transmission characteristics and loss of in-between connections in your CATV system.

LIMIT SETUP

Scroll to this parameter to set the limits of the meter so that you can conduct limit tests. Press **F1** to enter the LIMITS display. Here, you can select the LIMIT DISPLAY and edit the limits.

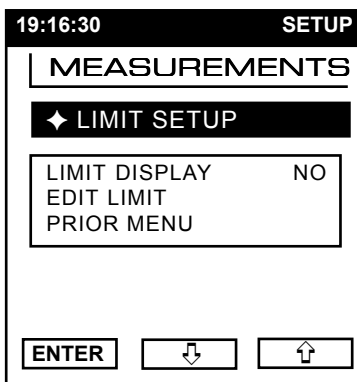

You can display the limit lines and a PASS/FAIL indication for each channel and the viewable scan spectrum, during channel spectrum scanning. Limits are not used to determine Pass or Fail for SGNL and DIGI type channels (see *Channel Spectrum Scanning Measurement* page 44). To enable or disable this function, scroll to LIMIT DISPLAY and then press **F1** to *toggle* the function from off to on (NO to YES).

NOTE: To print the Pass or Fail status of each channel on a report, set LIMIT DISPLAY to YES.

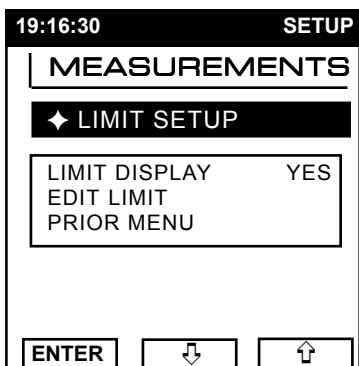

To edit the limits, scroll to EDIT LIMITS and press **F1**.

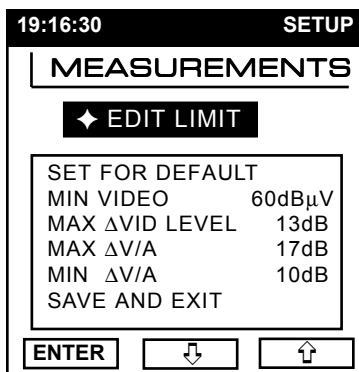

In this screen, you will need to select the minimum video level (40dB μ V to 120dB μ V), maximum Δ video level (2dB to 30dB), maximum Δ video/audio difference (5dB to 30dB), and minimum Δ video/audio difference (0dB to 15dB). To enter the levels, use **F2** or **F3** to scroll to each limit.

Press **FCN** to *toggle* the key pad to numeric entry mode.



Enter the desired level for the parameter. Press **F1** to save the parameter and move to the next limit.

NOTE: If you press **F2** or **F3** to scroll BEFORE you press **F1**, you will remain on the limit you just edited and the UP/DOWN key will delete the entry instead of moving to the next limit.

Once you have set the levels for each parameter, scroll to SAVE AND EXIT and press **F1**. The Model One returns to the LIMIT SETUP screen.

Once the limits are set, scroll to PRIOR MENU and press **F1** to return to the MEASUREMENTS setup screen.

FREQ TUNING STEP

Use the FREQUENCY TUNING STEP to select the meter's internal step values. These steps can be either 10 kHz, 100 kHz, 1 MHz or 10 MHz.

Use **F2** or **F3** to scroll to FREQ TUNING STEP and press **F1** (ENTER).

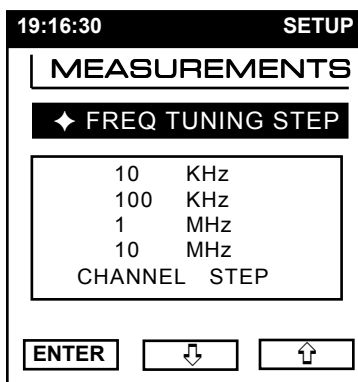

Use **F2** or **F3** to scroll to the desired tuning step. Press **F1** (ENTER) when the value you want is highlighted. The Model One will return to the MEASUREMENTS set up screen.

SIGNAL LEVEL UNITS

Use **F2** or **F3** to scroll to SIGNAL LEVEL UNITS. Press **F1** to enter the parameter display.

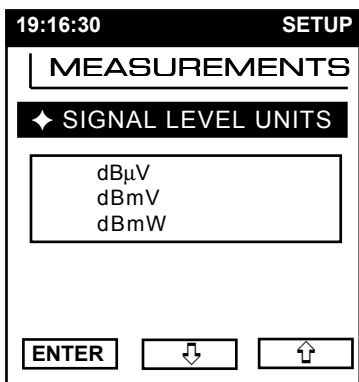

You may set the signal level units to test for dBμV, dBmV or dBmW. Scroll between the values with **F2** or **F3** and press **F1** when the desired value is highlighted. The meter will return to the MEASUREMENT display.

TEMPERATURE UNITS

Scroll to TEMPERATURE UNITS and press **F1**.

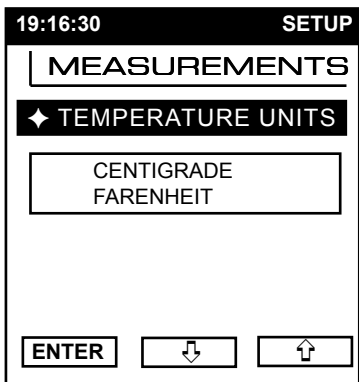

You may set the meter to read either Centigrade or Fahrenheit. Scroll between the two with the **F2** and **F3** buttons. Once the desired setting is highlighted, press **F1** to select the setting and return to the MEASUREMENT setup screen.

LOAD DEFAULT

Since the Model One has the capability to memorize and store its various parameters and settings, you may restore it to its initial default settings at anytime.

If you wish to restore the Model One to the default settings, scroll to LOAD DEFAULT and press **F1**. The meter will return to all of its default settings.

NOTE: If you select the LOAD DEFAULT command, the meter does not return to the MEASUREMENTS setup screen when you press **F1**.

Instead, it displays the INFORMATION screen briefly and then goes to the LEVEL display screen. To return to the MEASUREMENTS screen, press **SET** to return to the SETUP screen, scroll to MEASUREMENTS and press **F1** (ENTER).

PRIOR MENU

Once you have set up the Model One's parameters to the desired settings and values, use **F2** or **F3** to scroll to PRIOR MENU. Press **F1** (ENTER) to return to the SETUP display screen.

Channel Plan Display

One of the most useful functions of the Model One, is its ability to generate a user-selected Channel Plan based on your own specific system as well as provide you with existing default channel plans.

To enter the CHANNEL PLAN DISPLAY, go to the SETUP screen, scroll to CHANNEL PLAN and press **F1**.



LEARN CHANNEL PLAN

You can use either an existing channel plan that comes with the meter or use one of these to customize your own. To learn a channel plan, scroll to LEARN CHANNEL PLAN and press **F1**.

CAUTION: Before starting the learning session, make sure your Model One is hooked up to your CATV system.



Once the list of channel plans is displayed, use **F2** or **F3** to scroll through the list. When the desired channel plan is highlighted, press **F1**.

The meter searches for active channels in your system. A “progress bar” indicates search progress.

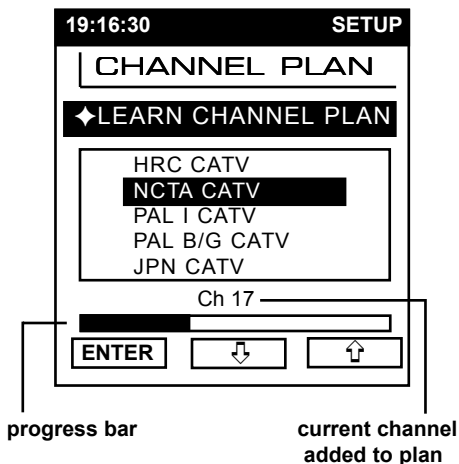

Once the search is completed, the Model One displays the prompt that the new channel plan is being saved. This channel plan contains all active channels. Those channels that did not transmit a signal will not be included.

EDIT CHANNEL PLAN

Once your channel plan has been learned, you may then modify the various parameters in the plan. Scroll to EDIT CHANNEL PLAN and press **F1**.



Within the EDIT CHANNEL PLAN display, use **F2** or **F3** to scroll through the list of channels. All channels that have been enabled by the LEARN CHANNEL PLAN will have a checkmark under ENA.

◆ EDIT CHANNEL PLAN			
CHN	TYPE	FREQ	ENA
14	TV	121.25	✓

When the desired channel you wish to modify is highlighted, press **F1** (ENTER).

19:16:30		SETUP	
CHANNEL PLAN			
◆ EDIT CHANNEL PLAN			
CHANNEL NUMBER	16		
ENABLED	YES		
TYPE	TV		
SCRAMBLED	NO		
FREQUENCY:	133.25MHz		
AUD OFFSET	4.50MHz		
SAVE AND EXIT			
ENTER	↓	↑	

To change the channel's parameters, use **F2** and **F3** to scroll up and down the list.

There are different methods for modifying each parameter.

NOTE: When using the **FCN** button, remember to press **F1** once you have made the desired edit. Otherwise, if you use **F2** or **F3** to scroll, you will change your modification rather than move to the next parameter.

Channel Number – When the channel number is highlighted, press **FCN** to enable the numeric key pad. Enter the desired number for the channel (0 - 199). Once the channel number is modified, press **F1** to save the edit. The Model One scrolls to the ENABLED edit line.

Enabled – When the ENABLED line is highlighted, press **F1** to *toggle* between on or off (YES or NO).

Type – Use **F1** to *toggle* between the channel types (TV, SIGL, or DIGI).

NOTE: The rest of the parameters in the edit list are affected by which type of channel you select.

TV – Audio and Video Carriers (parameters: Scrambled, Frequency, AUD Offset)

SIGL – Single Frequency Channels (parameters: Scrambled, Frequency)

DIGI – Digital Channels (parameters: Scrambled, Frequency, Measure BW)

Scrambled – Use **F1** to *toggle* between YES and NO.

Frequency – To change the video frequency of the channel, press the **FCN** button to enable the numeric key pad.

NOTE: The new frequency you enter should always be less than 870 MHz.

Once the desired modification is made, press **F1** to save the edit and exit the FCN mode.

AUD Offset (TV type only) – Use this parameter to change the positive offset of the audio frequency from the video carrier. When this parameter is highlighted, press the **FCN** button to enable the numeric key pad.

NOTE: The sum of this offset and the video carrier frequency should never be more than 870 MHz.

Once the desired modification is made, press **F1** to save the edit and exit the FCN mode.

Measure BW (Digi type only) – When this parameter is highlighted, press the **FCN** button to enable the numeric key pad. Once the desired modification is made, press **F1** to save the edit and exit the FCN mode.

When you have made the desired edits to the channel parameters, scroll to **SAVE AND EXIT** and press **F1**. The Model One returns to the **EDIT CHANNEL PLAN** screen.

NOTE: Once you have modified the channels in the existing plan, you will need to press a function button (i.e. **SET**) to exit the **EDIT CHANNEL PLAN** screen.

CAUTION: Whenever you learn a new Channel Plan, the previously edited parameters will be overwritten by the new plan and all files that were saved with the previous plan will be deleted.

TILT/FAVORITE

The Model One enables you to select up to eight “favorite” channels. These channels are also used when making the Tilt measurement.

NOTE: You must select at least **FOUR** channels to make the Tilt Measurement. The Model One uses the highest and lowest frequencies when making the measurement.

To enter the TILT/FAVORITE screen, scroll to TILT/FAVORITE and press **F1**.

19:16:30		SETUP	
CHANNEL PLAN			
◆TILT/FAVORITE			1
			2
			3
			4
			5
			6
			7
			8
CHN	FREQ	TILT	
14	121.25		
15	127.25		
16	133.25		
17	139.25		
18	145.25		
ENTER		↓	↑

To add a channel to the FAVORITES list, use **F2** and **F3** to scroll the list of channels. When the desired channel is highlighted, press **F1**.

A check mark appears next to the channel under the TILT column and the channel number is placed in the FAVORITES column on the right of the display.

19:16:30		SETUP	
CHANNEL PLAN			
◆TILT/FAVORITE			1
			2
			3
			4
			5
			6
			7
			8
CHN	FREQ	TILT	
14	121.25	✓	4
15	127.25		6
16	133.25	✓	14
17	139.25		16
18	145.25		
ENTER		↓	↑

favorites list

As you add channels, the FAVORITES list arranges them in order of their frequency. For example, even if you selected Channel 14 first, as you add Channels 4 and 6, these channels go to the top of the list.

Once you have selected up to eight favorite channels, press a function button (i.e **SET**) to exit the TILT/FAVORITE screen.

If you want to replace a TILT/FAVORITE channel, use **F2** or **F3** to scroll to the channel to be deleted. Press **F1**. Go to the replacement channels and press **F1**.

REMINDER: For the TILT MEASUREMENT feature to function, you must have at least FOUR channels in the FAVORITES list.

BASIC OPERATION

Introduction

Once you have set up the Model One's parameters, you are ready to operate the unit. The Model One supports a number of functions that are accessed via buttons on the key pad. There are eleven function buttons on the Model One's key pad.

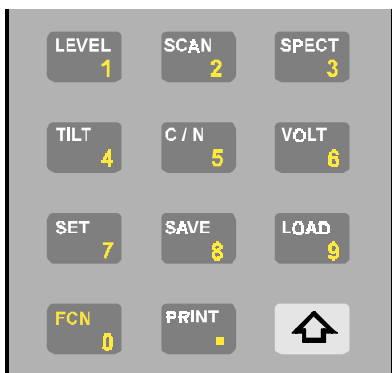

These include:

- Level – Enter Single Channel/ Frequency Measurement (see page 38)
- Scan – Enter Channel Spectrum Scanning Mode (see page 44)
- Spect – Enter Frequency Spectrum Scanning Mode (see page 48)
- Tilt – Enter Tilt Measurement Mode (see page 34 and page 51)
- C/N – Enter Carrier-to-Noise Ratio Measurement Mode (see page 51)
- Volt – Check Voltage (battery and power supply/drop) (see page 53)

- Set – Set Up Display Parameters (see page 17)
- Save – Enables you to save the display data or data record (see page 60)
- Load – Enables you to open previously saved display data or data record (see page 64)
- FCN – Puts the key pad into a second function (i.e. enables you to input numbers into a display) (see page 13)
- Print – Print display data or data record (see page 66)

NOTE: When you power ON your meter, it will display briefly the INFORMATION screen and then display the last screen it was in prior to power off.

Single Channel Level Test

When set to the single channel level test, the Model One displays bar graphs of the video and audio carriers as well as numeric readouts of the carrier amplitudes and V/A difference. The meter can also display a spectrum scan showing the amplitudes of the video and audio carriers and undesired signals that may be present such as intermodulation.

To access the LEVEL screen, press the **LEVEL** button.



The Model One displays the LEVEL screen for the last channel it was on before being turned off.

TV CHANNELS

When measuring a TV type channel with audio and video carriers (see *Edit Channel Plan* page 31), the left column of the bar graph represents the video carrier while the right column displays the audio carrier. The V/A Δ is displayed below the video and audio carriers.

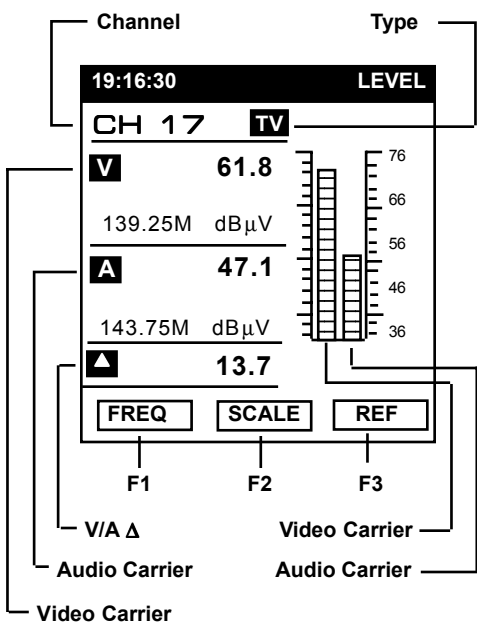

To change the channel, use the **UP** and **DOWN** arrow buttons on the keypad or press the **FCN** button and enter the desired channel number.

The LEVEL screen displays a scale which you can adjust by pressing **F2** (SCALE). This enables you to vary the graduation of the scale according to a 1, 2, 5, 10dB scale.

For example, to change the display graph from a 10dB scale to a 5dB scale, press **F2** twice to cycle through the steps.

Press

SCALE

to go from:

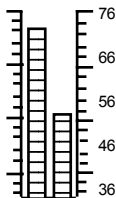

10dB

to

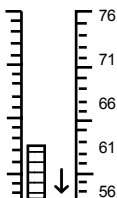

5dB

NOTE: The display graph of the scale adjusts as you change the scale parameters. When the value falls below the scale, the bar graph is replaced with an arrow.

You may also change the reference level of the graph. Press **F3** (REF) and then press **F1** (REF-) or **F2** (REF+) to increase or decrease the scale references a single digit at a time.

Press

REF

Press

REF -

or

REF +

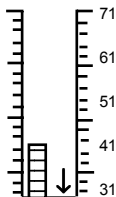
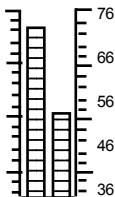

The Model One can scan the spectrum of the designated channel automatically. This function is particularly useful for CATV measurements.

To scan the channel spectrum, press **LEVEL** again. The Model One displays the spectrum screen and scans the channel for data which it then graphs on the screen.

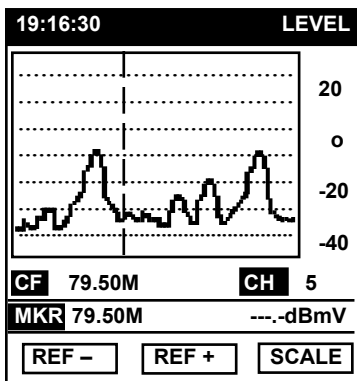

The Center Frequency and Channel Number are displayed along with the Marker Frequency and level.

Use the **UP** and **DOWN** arrow buttons to move the Marker Frequency to any position in the channel spectrum.

SINGLE FREQUENCY CHANNELS

You can use the Model One to measure only the Center Frequency. To do this, first set the meter's channel type to **SGNL** or single frequency channel (see *Edit Channel Plan* page 31).

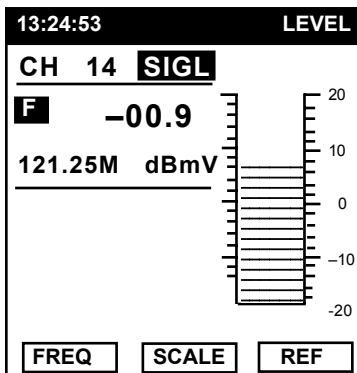

To scan the channel spectrum, press **LEVEL** again.

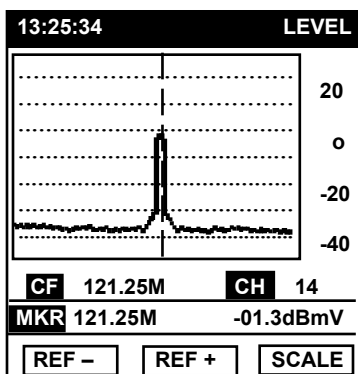

DIGITAL CHANNELS

You can use the Model One to measure the average power of a digital channel according to the configured bandwidth. To do this, first set the meter's channel type to DIGI (see *Edit Channel Plan* page 31).

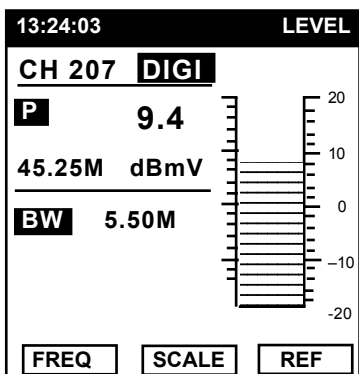

To scan the channel spectrum, press **LEVEL** again.

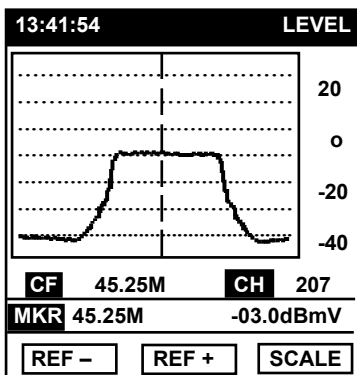

Frequency Mode

When set to the FREQUENCY Mode, the Model One displays the frequency and level for the desired channel.

To access this screen, press the **LEVEL** button.



The SINGLE CHANNEL LEVEL screen is displayed.

Now, press **F1** (FREQ).

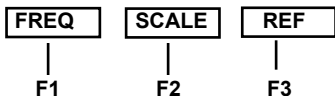

This *toggles* the meter so that it displays the FREQUENCY screen for the channel designated in the SINGLE CHANNEL LEVEL screen.

If the channel is a “TV” type channel with audio and video carriers, the meter will be tuned to the audio frequency. Also, if the volume has been set in the GENERAL SETUP menu, Audio will be heard in this FREQUENCY Mode.

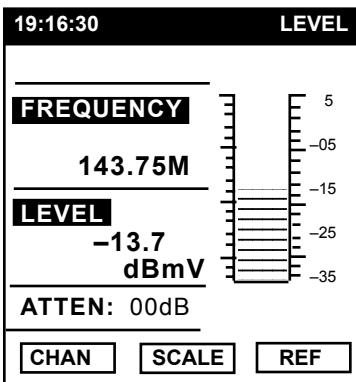

To change the frequency that is being measured, press the **UP** and **DOWN** arrow buttons on the keypad. The frequency will move in increments set in the MEASUREMENTS SETUP menu.

NOTE: By pressing the **FCN** button, you can enter the desired frequency. To finish, press **F1** (ENTER).

Press **F2** (SCALE) to adjust the display scale in 1,2,5,10dB increments (see page 40).

To adjust the reference level, press **F3** (REF) and then **F1** (REF-) or **F2** (REF+) (see page 40).

Channel Spectrum Scanning Measurement

The Model One is designed to display the full span of the video carriers in your system. This function provides a quick check of your system's overall flatness and amplitude.

The meter can also be set to display the video and audio carriers at reduced frequency spans. Amplitude limits can be imposed on the display while a convenient Frequency Marker enables you to *zoom* in on any suspect channels.

To enter the CHANNEL SPECTRUM SCANNING screen, press **SCAN**.



The currently selected channel plan measurement data is displayed in a graph with a viewing range of 100 data points (this can be extended to 140 by adjusting the Scan Marker line).

NOTE: If Scan Audio is selected, 50 channels (audio and video) are viewable at a time.

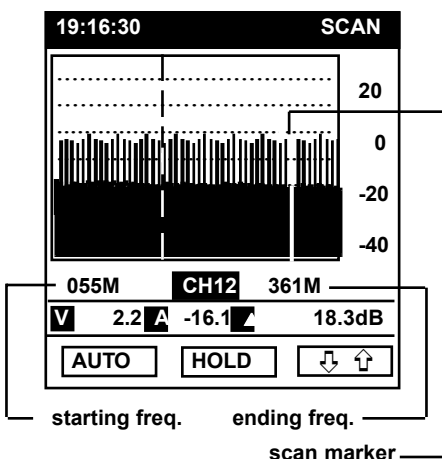

In addition to displaying the Marker Channel and its video, audio and V/A Δ levels, the Model One also displays the LOW (starting) and HIGH (ending) frequencies.

CHANNEL SPECTRUM SCANNING supports four methods based on the parameters selected in the MEASUREMENT setup screen (see page 23):

- SCAN ENABLE = YES - the meter scans only the active (selected) channels in the user-selected Channel Plan (see page 29)

- SCAN ENABLE = NO - the meter scans all channels
- SCAN AUDIO = NO - the meter graphs only the video carriers of the channels (numeric readout of video and audio levels are displayed for the marker channel)
- SCAN AUDIO = YES - the meter graphs both the video and audio carriers of the channels (numeric readout of video and audio levels are displayed for the marker channel)

To change the channel being scanned, press the **UP** or **DOWN** arrow buttons.

NOTE: You can increase the marker movement resolution by pressing **FCN** before pressing the **UP/DOWN** arrow buttons to quickly move the marker across the full channel plan spectrum. Pressing **FCN** again before using the **UP/DOWN** arrow buttons causes the marker to return to a movement of one channel at a time.

You can zoom in on the graph by pressing the **SCAN** button. The Model One supports 5 levels of magnification. To return to the original zoom level, just keep pressing **SCAN** to cycle back.

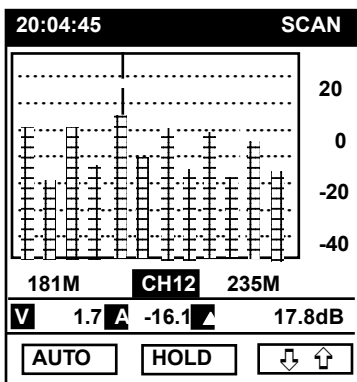

To set the reference level and the scale automatically, press **F1** (AUTO). The Model One will select the optimal scope for your system.

If you prefer to set the reference level and scale yourself, press **F3** (↓, ↑) (see page 40 for more information).

To adjust the reference level, press **F1** (REF) and then press **F1** (REF-) or **F2** (REF+).

To change the scale, press **F3** (↓, ↑) from the main CHANNEL SPECTRUM SCANNING screen and then press **F2** (SCALE) until you have selected the desired scale (2, 4, 10, or 20dB).

At any time, you can restore the Model One to the optimal levels by pressing **F1** (AUTO).

You may wish to stop the scanning process so that you can study the graph without losing the current data. In the main CHANNEL SPECTRUM SCANNING screen, simply press **F2** (HOLD). The scanning marker will stop moving. To resume scanning, press **F2** (TRIG).

LIMIT DISPLAY

If LIMIT DISPLAY is set to YES in the MEASUREMENTS menu (see *LIMIT SETUP* page 25), the Channel Spectrum Scanning display will show the limit lines for the minimum video level and maximum Δ video level.

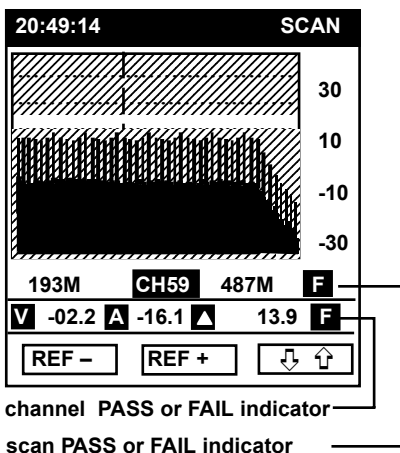

A “P” for PASS or “F” for FAIL appears for each channel selected by the marker. This indicates that the channel meets the requirements which were set up in the LIMITS EDIT menu: minimum video level, maximum Δ video level, maximum Δ video/audio difference, and minimum Δ video/audio difference (see page 26).

A PASS (P) or FAIL (F) indication is also given for the displayed scan spectrum. This will indicate “-” until the first scan is completed. The channel status of a “DIGI” or “SNGL” type channel is not used to determine PASS or FAIL for the scan. This is used ONLY for “TV” type channels with audio and video carriers.

NOTE: A “pass/fail” status is not available for single or digital channels.

Frequency Spectrum Scanning Measurement

The Model One can be set to display spectrum measurements with spans ranging from 2 to 50 MHz. It can also be set for a full spectrum scan (5 to 870 MHz) with sampling at each video carrier frequency in the selected channel plan.

NOTE: The Model One can show spectrum data with absolute measurements or it can store data for comparative tests using the TRANSMISSION feature.

TRANSMISSION mode is set up in the MEASUREMENTS menu. Since the following data is for normal (absolute) spectrum scanning, TRANSMISSION should be set to NO in the MEASUREMENTS menu (see page 25). For further information on TRANSMISSION OPERATION, see *TRANSMISSION CHARACTERISTIC TEST* page 55.

The following information is for normal (absolute) spectrum scanning.

To enter the FREQUENCY SPECTRUM SCANNING screen, press **SPECT**.



The FREQUENCY SPECTRUM SCANNING screen is displayed.

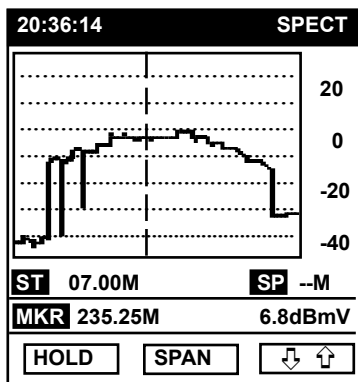

When the full spectrum scan is displayed, the SPAN indicator will be "--M" (full span). The starting frequency will be shown along with the marker frequency and level.

To move the marker frequency, press the **UP** or **DOWN** arrow buttons on the keypad.

To change the scanning bandwidth, press **F2** (SPAN). The span cycles through 2M, 5M, 10M, 20M, 50M and --M (full span).

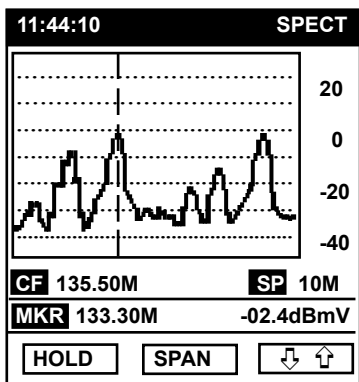

When a span other than full span (--M) is selected, the display shows the center frequency.

To change the center frequency, press **FCN** to place the keypad in its second function. Enter the desired new center frequency and press **F1** (ENTER).

If you enter an incorrect digit, do not press **F1**. Instead, press **F2** (BACK). You can exit the procedure by pressing **F3** (ESC) to return to the original center frequency.

To change the reference levels, press **F3** (↓, ↑), press **F1** (REF) and then press **F1** (REF-) or **F2** (REF+).

To change the scale, press **F3** (↓, ↑) from the main FREQUENCY SPECTRUM SCANNING screen and then **F2** (SCALE).

If you want to stop the scanning process, simply press **F2** (HOLD). The channel marker will stop moving. To resume scanning, press **F2** (TRIG).

Carrier-To-Noise Measurement

To enter the C/N screen, press **C/N**.



The meter displays the C/N RATIO screen.

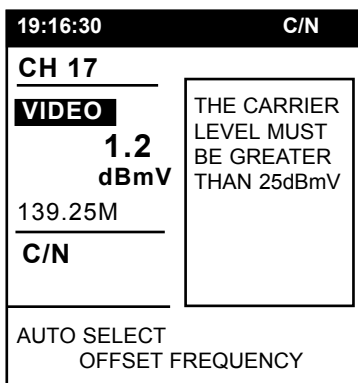

The meter measures the C/N difference of the selected channel. First, it measures the video carrier level of the selected channel.

NOTE: The video carrier level **MUST** be greater than 25dBmV (85dB μ V).

If the measured video carrier is greater than 25dBmV (85dB μ V), the meter will display a “please wait...” message prompt.

Then, the meter measures the noise level in the guard band of that channel and calculates the measurement of the affected channel. The value of the C/N difference is displayed on the screen.

Tilt and Favorite Channel

When installing and maintaining your CATV system, you may want to concentrate on only a few channels' levels and the gain distribution of the transmission line.

You can use the TILT and FAVORITE CHANNEL function to display and adjust the level and work status of your system.

To enter the TILT AND FAVORITE CHANNEL screen, press **TILT**.



REMINDER: Before you use the TILT AND FAVORITE CHANNEL feature, you must enter at least FOUR channels in the TILT/FAVORITE section of the CHANNEL PLAN set up screen (see *TILT/FAVORITE* page 34).

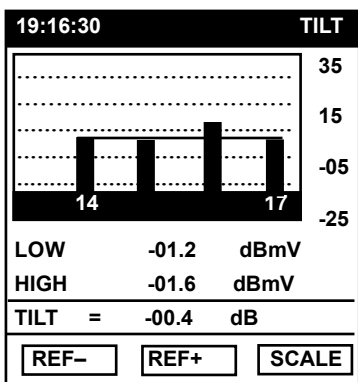

The measured levels of the LOWEST and HIGHEST frequencies listed in the TILT/FAVORITE list are used to calculate tilt.

To adjust the reference level, press **F1** (REF-) or **F2** (REF+). (See page 40.)

To change the scale, press **F3** (SCALE). (See page 40).

To bring up the list of favorite channels, press **TILT** again.

19:16:30	FAVOR
CH 14	-00.8
CH 15	-01.7
CH 16	0.6
CH 17	-01.2

The Model One displays the list of favorite channels with their video carrier levels.

NOTE: You may list up to eight favorite channels. See *TILT/FAVORITE* page 34 for set up procedures.

Battery and Trunk Voltage Measurement

The Model One is equipped with a built-in Voltmeter which can be used to troubleshoot problems with power supplies or power drops. The meter accommodates AC or DC voltages up to 120 Volts.

To enter the VOLTAGE screen, press **VOLT**.



The VOLTAGE screen displays two bar graphs.

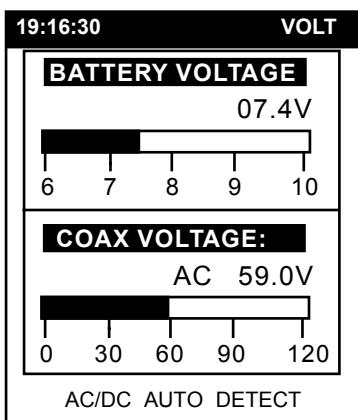

The top bar graph indicates the battery voltage of your meter. As you use it, you can access this screen to check the remaining battery power of your unit.

When the voltage of the battery drops below 6.4V, the battery symbol *flashes* in the information line at the tip of the display screen.

**Flashing battery symbol
indicates low voltage**



If the voltage drops below 6.2V, the Model One shuts off automatically to protect the battery. See *BATTERY CHARGING* on page 14.

The lower bar graph indicates the AC or DC voltage of the system's trunk.

Now that you have a better understanding of how to use the Model One's basic features, you may turn to the advanced functions (see *Chapter 5* page 55) such as testing for transmission characteristics, dVB (QAM) channel measuring, saving records, printing operations, etc.

ADVANCED OPERATION

Introduction

Once you have studied the Model One's basic operation (see *Chapter 4* page 37), you can proceed with more complex operations.

Transmission Characteristic Test

The Model One enables you to test for the transmission characteristics of your CATV device via its scanning frequency network analyzer function. One of the primary needs of a CATV system is to ensure the quality of the signal transmission.

The meter enables you to do this by measuring the gain distribution of the transmission line and loss insertion by measuring the transmission characteristics and loss insertion for cable, branch line, distributor, amplifier, etc. The Model One utilizes the signal of your CATV headend to achieve this.

To test the transmission characteristics, you first need to enable the TRANSMISSION option.

Press the **SET** button.



Press **F2** or **F3** to scroll to MEASUREMENTS and then press **F1** (ENTER) to select that screen.

Use **F2** or **F3** to scroll to TRANSMISSION. Press **F1** (ENTER) to *toggle* the transmission function to YES. The YES selection indicates that the meter is in TRANSMISSION Mode.

When you press **F1** (ENTER), the Model One displays the following prompt:

19:16:30	SETUP	
MEASUREMENTS		
SCAN AUDIO	NO	
DO YOU WANT TO REPLACE INITIAL SPECT DATA?		
FREQ TUNING STEP		
SIGNAL LEVEL UNITS		
TEMPERATURE UNITS		
PRIOR MENU		
◆ LOAD DEFAULT ◆		
YES	NO	ESC

When the meter displays the prompt, you have the option to replace the initial spectrum data with a new spectrum reference or to use the original zero reference level in memory.

If you wish to use the original zero reference level, press **F2** (NO) or you may exit this screen by pressing **F3** (EXIT).

If you press **F2** (NO), the meter displays the following prompt:

19:16:30	SETUP	
MEASUREMENTS		
SCAN AUDIO	NO	
PRESS F1 KEY FIRST TO PROCESS TRANSMISSION MEASURE		
FREQ TUNING STEP		
SIGNAL LEVEL UNITS		
TEMPERATURE UNITS		
PRIOR MENU		
◆ LOAD DEFAULT ◆		
ENTER	BACK	

Connect the CATV source to the Model One and press **F1** (ENTER).

The Model One will display the transmission measurement. The scale indicates Δ dB to show the difference between the current CATV source and the spectrum reference in memory.

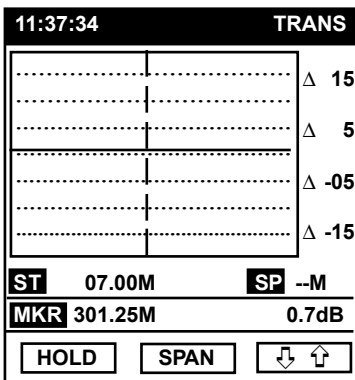

To replace the initial spectrum data, set the TRANSMISSION selection (in the MEASUREMENTS setup menu) to YES. When the display reads “Do you want to replace initial spect data?” press **F1** (YES). The meter displays the prompt:

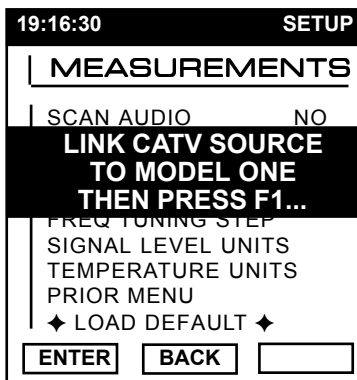

Connect the CATV source for the new reference spectrum to the Model One and press **F1** (ENTER).

The Model One scans the level automatically according to the frequency of the video carrier which has been set in the Channel Plan (see *CHANNEL PLAN DISPLAY* page 29).

The Model One then displays:

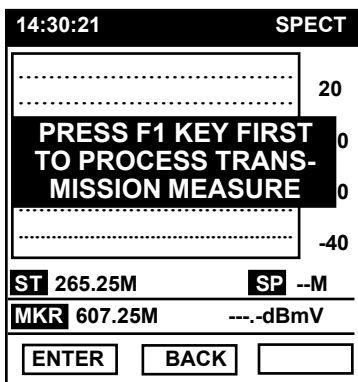

NOTE: If you wish to perform another spectrum scan for the new reference, press **F2** (BACK).

Press **F1** (ENTER) to proceed. The Model One will perform another spectrum scan and compare it to the reference scan.

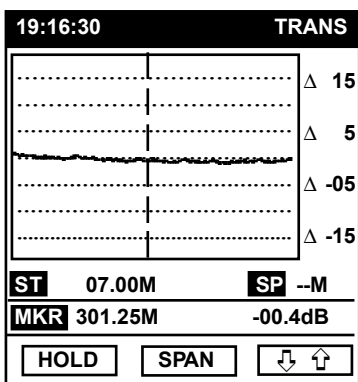

In the TRANSMISSION screen, the zero reference level is displayed as a line in the middle of the screen.

The scale indicates Δ dB to show the difference between the new spectrum scan and the reference spectrum data. The reference remains in the meter's non-volatile memory even when the Model One is turned off. This enables you to measure the level's relative change at a later time.

To perform a new TRANSMISSION TEST at any time, confirm that TRANSMISSION is set to YES in the MEASUREMENT set up menu (see page 25) and then press **SPECT**.

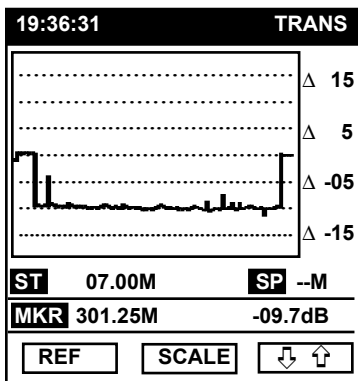

The Model One will perform a spectrum scan and compare it to the reference data. In this example, a 10dB loss is seen at each active video carrier sampled in the spectrum scan.

Press the **UP** or **DOWN** arrow buttons on the key pad to move the marker frequency.

NOTE: The SPAN function does NOT operate when the meter is in the TRANSMISSION mode.

For normal (absolute) spectrum measurements, set the TRANSMISSION selection to NO in the MEASUREMENTS set up menu (see page 25).

Saving Data

The Model One enables you to save the channel spectrum measurement data (see *Channel Spectrum Scanning Measurement* page 44).

NOTE: This meter can save 48 or more groups of data. Each group may include the level value of the video carrier for 140 channels or the level value of both the video and audio carriers for 70 channels.

To save data, press **SAVE**.



19:16:30		SAVE
NAME	DATE	TIME
FILE0	14/07/00	13:15
FILE1	14/07/00	13:30
FILE2	15/07/00	10:12
FILE3	16/07/00	11:16
FILE4		
FILE5		
FILE6		
FILE7		

ENTER ↓ ↑

Use **F2** and **F3** (arrows) to scroll to the file line to which you want to save the data.

NOTE: If you select a file to which data has already been saved, the meter will overwrite the old data with the new data.

If you wish to scroll in screen blocks instead of file by file, use the **UP** and **DOWN** arrow buttons on the key pad.

Press **F1** (ENTER).

19:16:30		SAVE
NAME	DATE	TIME
FILE0	14/07/00	13:15
DO YOU WANT TO SCAN AND SAVE ALL CHANNELS?		
FILE4		
FILE5		
FILE6		
FILE7		
YES	NO	ESC

To perform a channel scan to be saved, press **F1** (YES). The meter will scan all the channels in the designated Channel Plan (see page 29).

To save the existing scan shown in the SCAN mode, press **F2** (NO). The meter will display the FILE INFORMATION screen.

19:16:30		SAVE
◆ FILE05 INFORMATION		
DATE:	14/07/00	
TIME:	13:39:27	
START CHANNEL:	201	
DATA NUM	ALL	
SCAN AUDIO:	YES	
SCAN ENABLE	NO	
NOTE:		
SAVE	EXIT	NOTE

The saved data includes:

- Date - the date the file was saved
- Time - the time the file was saved
- Start Channel - the number of the first or starting channel in the scan

- Data Num - the number of valid data displayed
- Scan Audio - whether or not the audio was scanned
- Scan Enable - whether the active channels ONLY in the channel plan were scanned
- Note - user-entered notation for the file

FILE NOTATION

Before you save the file, you may make a brief notation.

While in the FILE INFORMATION screen, press **F3** (NOTE).

The screenshot shows a terminal window titled "NOTE" with a timestamp "19:16:30". Inside the window, there is a box containing three lines of characters: "() * + , - . / 0 1 2 3 4 5 6 7 8 9", ":", ";", "<=", ">=", "[] A B C D E F G H I J K", and "L M N O P Q R S T U V W X Y Z ? ↵". Below this box, the text "PLEASE INPUT NOTE:" is displayed above a horizontal line. At the bottom of the window, there are three buttons: "ENTER", "<", and ">".

To enter your notation, press **F2** (<) and **F3** (>) to scroll along the three alphanumeric character lines. To scroll from one line to the next, use the **UP** and **DOWN** arrow buttons on the keypad. As each desired letters and numbers is highlighted, press **F1** (ENTER). The character appears on the line below PLEASE INPUT NOTE. When you are finished, scroll to the “arrow” character (appears after “Z” and a blank) and press **F1** (ENTER).

For example, to enter Hub 1, use the **DOWN** arrow button to highlight the middle line. Press **F3** (>) to highlight “H”. Press **F1** (ENTER). “H” appears on the line.

Use the **DOWN** arrow button to highlight line 3 and **F2** (<) to scroll to “U”. When it is highlighted press **F1** (ENTER) and “U” will appear on the line next to “H”. Press the **UP** arrow button twice to scroll up to line 1. Use **F2** (<) or **F3** (>) to highlight “B” and press **F1** (ENTER).

To create a space, use the **DOWN** arrow to scroll to the third line and press **F3** (>) to take the cursor to the blank after the letter “Z”. Press **F1** (ENTER).

Return to line 1, highlight the numeral “1”, and press **F1** (ENTER).

The notation line should appear as follows:

PLEASE INPUT NOTE:
HUB 1

Once your note is ready, scroll to the “arrow” character (after the Z and blank) and press **F1** (ENTER). The meter returns to the SAVE screen and your notation appears next to NOTE:.

19:16:30		SAVE
◆ FILE05 INFORMATION		
DATE:	14/07/00	
TIME:	13:39:27	
START CHANNEL:	201	
DATA NUM	ALL	
SCAN AUDIO:	YES	
SCAN ENABLE	NO	
NOTE:	HUB 1	
SAVE	EXIT	NOTE

When you are satisfied with the status of the file's information, press **F1** (SAVE). The Model One saves the file and then returns to the initial SAVE screen.

The new file's date and time appears next to the file number.

19:16:30		SAVE
NAME	DATE	TIME
FILE0	12/07/00	13:15
FILE1	12/07/00	13:30
FILE2	13/07/00	10:12
FILE3	13/07/00	11:16
FILE4	14/07/00	09:29
FILE5	14/07/00	14:18
FILE6		
FILE7		

ENTER ↓ ↑

Loading Data

The Model One enables you to load data you have saved previously.

Press **LOAD**.



19:16:30		LOAD
NAME	DATE	TIME
FILE0	12/07/00	13:15
FILE1	12/07/00	13:30
FILE2	13/07/00	10:12
FILE3	13/07/00	11:16
FILE4	14/07/00	09:29
FILE5	14/07/00	14:18
FILE6		
FILE7		

ENTER ↓ ↑

Press **F2** and **F3** to scroll to the desired file. You may also scroll in screen blocks using the **UP** and **DOWN** arrow buttons on the key pad.

When the desired file is highlighted (i.e. FILE5), press **F1** (ENTER).

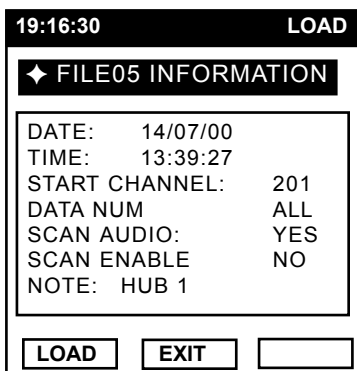

Once the desired FILE INFORMATION screen is displayed, press **F1** (LOAD).

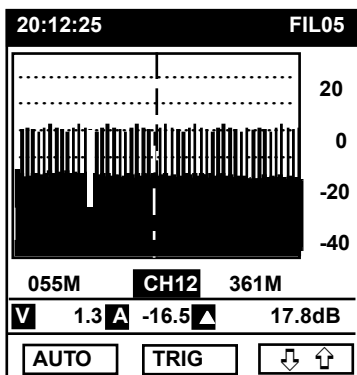

The meter displays the selected file.

To change channels, press the **UP** or **DOWN** arrow buttons on the key pad.

Press **F2** (TRIG) to go to a live SCAN mode.

If the LIMIT DISPLAY in the LIMIT SETUP screen (see page 25) is set to YES, the amplitude limits will be imposed on the screen.

“P” (PASS), “F” (FAIL) or “---” for untested (non-TV type channel) will be displayed to indicate that the marker channel meets all of the limits set up in the EDIT LIMIT screen (see page 26).

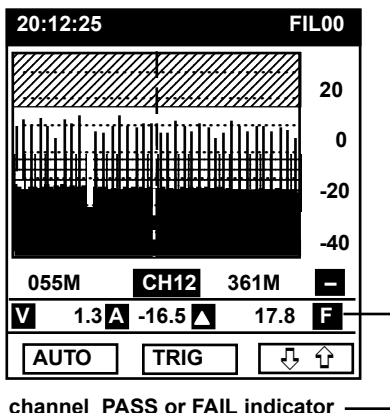

NOTE: The limits status indicator for the entire displayed scan spectrum does not function when you view a file with the LOAD feature.

Printing Operation

The Model One enables you to print either reports or screens to a serial printer or reports to a parallel printer.

NOTE: In order to use the printer feature, you will need a special cable (see page 4).

Once you have the required printer cable, connect it to the **PC/PRINTER INTERFACE** on the bottom of your unit. Connect the other end per the instructions for serial or parallel printer.

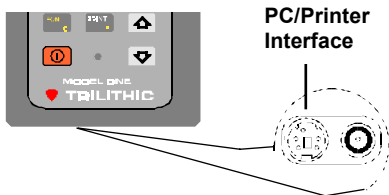

SERIAL PRINTER

To connect to a serial printer (such as an Epson LX-300), you will need:

- Printer Cable - P/N 2071352000 (5-pin circular connector to 25-pin D-sub-male connector)

Connect the 5-pin circular end to the Model One and the 25-pin connector to the printer.

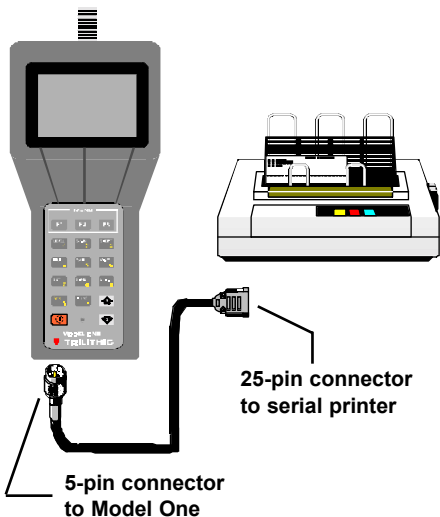

Set up the meter to print either the displayed screen or a report (see *PRINTER SETUP*, page 22).

NOTE: In the PRINT REPORT mode, a saved file must be recalled with the LOAD command before that report can be printed. If a saved file is not recalled, a report of the current scan status is printed. For more information, see *SAVING DATA*, page 60 and *LOADING DATA*, page 64.

Press the **PRINT** button to begin print operation.



PARALLEL PRINTER

To connect to a serial printer, you will need:

- Data Cable - P/N 2071351000 (5-pin circular connector to 9-pin D-sub-female connector)
- Parallel Printer Adaptor - P/N 0440202000 (9-pin D-sub-male to 25-pin D-sub-female connector)

Connect the Data Cable's 5-pin circular end to the Model One and the 9-pin connector to the 9-pin connection of the Parallel Printer Adaptor. Then, connect the 25-pin connection of the Parallel Printer Adaptor to the 25-pin cable connected to your printer.

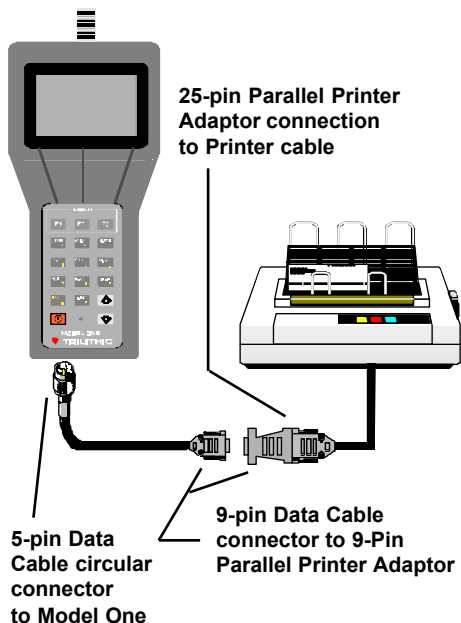

Set up the meter for the PRINT REPORT function (see *PRINTER SETUP*, page 22).

NOTE: In the PRINT REPORT mode, a saved file must be recalled with the LOAD command before that report can be printed. If a saved file is not recalled, a report of the current scan status is printed. For more information, see *SAVING DATA*, page 60 and *LOADING DATA*, page 64.

Press the **PRINT** button to begin print operation.



SPECIFICATIONS

Frequency Range	5MHz~870MHz
Tuning Resolution	10kHz
LEVEL Mode	
Signal Measurement Range	-25dBmV to +60dBmV 35dB μ V to 120dB μ V
Measurement Resolution	0.1dB
Measurement Accuracy :	
LEVEL Mode	\pm 1.5dB at 25 C
SCAN Mode	\pm 2dB at 25 C
Variation with Temp.	\pm 2dB from -10 C to +40 C
TILT/FAVORITE Mode	
Number of Channels	Up to 8, user-selected
Data Display	Bar graph or list of measured levels
TILT Measurement	Calculated as the difference in amplitude between the first and last carriers in the displayed group
SCAN Mode	
Channels Scanned	Up to 140, maximum
Scanning Rate	3 channels/second
Displayed Amplitude Range	80dB, maximum
Vertical Display	1, 2, 5, 10dB/division
Frequency Span	Settable from approximately 100MHz span to full span in 5 ranges
SPECTRUM Mode	
Displayed Amplitude Range	80dB, maximum
Frequency Span	Settable from 2MHz to 50MHz, in 5 steps or full span.
Amplitude Scale	1, 2, 5, 10dB/division
CARRIER/NOISE Function	
Measurement Range	Up to 50dB (with +25dBmV signal)
Measurement Accuracy	\pm 2dB typical
Measurement Resolution	0.1dB

VOLTAGE MEASUREMENT

Function

Input Range	0 – 120V, AC or DC
Measurement Accuracy	± 1V
Measurement Resolution	0.1V

LOAD (Data Logging)

Function

Number of Records	24 min. (48 with video only)
PC Upload Interface	RS-232C
Record Identification	Record number, date, time, and note

Miscellaneous

Size	21.8 cm x 9.5 cm x 4.9 cm
Weight	1.5 lbs
Display	128 pixel x 128 pixel backlit LCD
Power	Internal battery, approximately 4 hours operation per charge. AC Power cube



TRILITHIC

The Best Thing on Cable

9202 E. 33rd St.
Indianapolis, IN 46235
(317) 895-3600