



9581 SST R3

**OPERATION
MANUAL**

General Information

Introduction	3
SST Headend Unit	4
Equipment	5

Optimizing the Return Path

Introduction	6
Return Path Performance Parameters	7
Signal-to-Noise Ratio	7
Signal-to-Ingress Ratio	7
A Balanced System	9

About Your 9581 SST R3

9581 SST R3 System Overview	10
Theory of Application	11
Balancing the Return Path	11
Measuring Ingress and Noise	11

Installing the 9581 SST R3

Introduction	13
SST Headend Unit Installation	13
Reverse Test Carriers	14
Forward Data Carrier	15
Installation Procedure	16
Forward Connections	16
Reverse Connections	17
SST With Two Input Ports	17
SST With Test Point Manager Option	17

Setting Up the 9581 SST R3

Introduction	18
9581 SST R3 Onscreen Help	18
Power Up	19
Set Up	20
RX Freq	21
RX Level	22
Link Freq	23
Link Level	24
Fast Mode	25
Peak Hold	26
Detector Mode	26

Adjust Contrast	28
Exit Setup Menu	29
Basic Operation	
Introduction	30
Sweep Mode	30
Gain/Tilt Mode	31
Spectrum Mode	32
Fast Spectrum Mode	33
Remote Mode	34
Advanced Operations	
Introduction	35
Adjusting the Fiber Link	36
Adjusting Amplifiers	38
Ingress.....	39
Feature Notes	
Interoperability	42
Extending the Measurement Range	42
Reconfigure SST for Greater Range	43
Increase Sensitivity and Range	43
Effect of Offset on SSR Units	44
Effect of Offset on RSVP Units	44
Specifications	
9581 SST R3 Specifications	46

GENERAL INFORMATION

1

Introduction

Any CATV operator who maintains a two-way CATV distribution system knows that many factors can affect the performance of that system. Cumulative noise, signal ingress*, incorrect gain or bad flatness all conspire to harm the return path which can lead to loss of service and customer complaints.

You have taken an excellent step toward alleviating the problems of your return path with your purchase of this **9581 SST R3 Return Path Maintenance System**. Trilithic's 9581 SST R3 is the next generation of the 9580. It is designed to monitor all of the troublesome parameters in a single, simple to use system. The 9581 SST R3 is part of Trilithic's **Guardian Return Alignment System** which includes the 9581 SST R3, 9580 SSR, RSVP Installer Return Test Units and Isometer (for more information, refer to the operating manuals for the 9580 SSR, RSVP and Isometer).

The 9581 SST R3 differs from the 9580 in several ways:

- Extended frequency coverage up to 65 MHz
- Addition of eight more test points by combining the function of two SST units in one enclosure.

The 9581 SST R3 is designed with two forward telemetry transmitters which makes it appear as two 9580 SSTs. This ensures that the unit is compatible with the earlier versions of the 9580 system. The setup parameters for nominal level, coupler value and detector mode are common for both the SSTs. Test frequency, link frequency, and gain/tilt frequencies are treated independently for each SST.

It is more than just a return alignment system, however. The system also monitors the total performance of the return path by evaluating ingress and return noise. With the 9581 R3 SST's FAST Mode, you can increase the effective scanning rate of the INGRESS Mode's spectrum analyzer. This enables you to catch the transient events. PEAK HOLD enables the Unit to display the highest ingress points in NORM or FAST Modes. This makes the SST a powerful tool for capturing transient ingress. The AVERAGING feature is an option you can get for the SST. It is used in FAST Mode to reduce the noise floor displayed on the SST when measuring CW or common path. The digitizer for the 9581 SST R3 handles 42 MHz in a single band and 65 MHz in two bands.

The 9581 SST R3 can be equipped with the **TraffiControl** option. This feature equips the 9581 SST R3 to measure and plot the ingress spectra of bands occupied by return traffic. TraffiControl automatically filters all the "desired" signals from scanned return spectra so that only the ingress spectrum remains (see *DETECTOR MODE* page 29 for more information).

The basic 9581 SST R3 system consists of two types of equipment:

- SST Headend Unit (contains two SSTs in one enclosure)
- SSR Field Unit

A system may include more hardware including additional SSR Field Units, RSVP Installer Return Test Units and a variety of headend options.

SST Headend Unit

The SST Headend Unit is compact; occupying only 3.5" of rack space. It is easy to set up and operate. A single SST Headend Unit can support up to twelve SSR Field Units at a time with no loss of operating speed.

When it is equipped with two optional Test Point Manager (TPM-8), the SST analyzes sweep and ingress signals from up to sixteen separate test points individually. It sends the appropriate ingress spectrum and sweep data to each SSR Field Unit to which it is connected.

Even when it is not supporting the SSR Field Units, the SST can function as a monitor for return path quality. In attended headends, the personnel can observe noise and ingress patterns using the SST's built-in LCD display panel as an aid to trouble-shooting. Unattended locations can be monitored since the SST, when equipped with the Communications Manager option (NCM-4 or ACM-8), can send ingress and sweep measurement data via direct connection, phone lines, ethernet or fiber to a PC located in a central office (see *INGRESS MANAGER 2.X OPERATION MANUAL* for more information). Monitoring installations are easily expanded since the Communications Manager enables additional SST Headend Units to be accessed through a single connection. This means that a number of test points (32 with the NCM-4; 64 with the ACM-8) may be monitored without having to reconfigure the equipment connections.

Equipment

The 9581 SST R3 Return Path Maintenance System comes with the following standard items:

- SST Headend Unit (2 units in one enclosure)
- Operation Manual:
- 9581 SST R3 (1)

In addition to the standard equipment, you can also purchase the following:

- Additional SST Headend Units
- SSR Field Units (Carrying Bags included)
- RSVP Installer Return Test Units
- Communications Manager option (NCM-4/ACM-8) - allows multiple SST's (32 nodes via the NCM-4; 64 nodes via the ACM-8) to share a communications link (phone via modem, Ethernet, Fiber)
- Test Point Manager option - equips SST so that it can monitor up to 8 individual Headend test points - each SST 9581 SST R3 can handle two TPMs for a total of 16 test points
- Replacement NiCad battery pack (SSR Field Unit)
- Replacement Power Cube (SSR Field Unit)

OPTIMIZING THE RETURN PATH

2

Introduction

Before you begin using your 9581 SST R3 system, let's review the theory behind return path alignment and maintenance. To provide complex interactive services on cable, operators must ensure that they provide a reliable return path or customers won't have access to pay services, which will result in a loss of business. The high power transmissions from CB, ham radio and shortwave operators in the 5 to 30 MHz range, as well as other RF noise generating devices, present a threat to the return path as they can enter the cable system and interfere with upstream traffic. Additionally, the ever present signals from AM broadcast can enter the cable system and increase the power loading on the return laser to problematic levels.

As the return paths converge on their way to the headend or node, they act as interference concentrators. The various sources of ingress tend to add together and these independent sources of noise can merge to form a single strong ingress where the branches converge.

Since return path problems get worse as the branches converge, the best place to measure return path performance is at the headend; just before the upstream data is recovered. Return path performance monitored at the headend needs to be available to the technician in the field for alignment and troubleshooting. The 9581 SST R3 system simplifies this process as follows:

The SST Headend Unit measures the system ingress as well as the test signals from the SSR Field Unit(s) and then transmits the results as data back to the SSR Field Unit(s), thus enabling the field technician to align the system and trouble shoot ingress problems from anywhere in the system.

Return Path Performance Parameters

Reliable upstream performance depends upon:

- Proper Gain and Tilt
- Adequate signal-to-ingress ratio

It is important to balance Gain and Tilt in order to get the optimum performance from your system. Refer to Figure 1 on page 10.

SIGNAL-TO-NOISE RATIO

Gain in a particular branch, if set either high or low, can adversely affect the signal-to-noise ratio in some part or all of the return path.

If set low, signals on this branch could be “swamped” by the noise of other branches.

If set high, noise on this branch might be amplified enough to interfere with signals on other branches.

To minimize noise-induced communications errors, upstream data systems use robust modulation schemes like Quadrature Phase Shift Keying (QPSK) which typically operates at a data rate of 1.544 Mbps.

However, even when using QPSK as the modulation format, your return system must provide a signal-to-noise ratio of at least 10 dB, as measured in a 1 MHz bandwidth around the data carrier center frequency to provide a marginally adequate Bit Error Rate (BER) of $10E-5$

Incorrect gain settings, in some or all of the return paths, degrade the signal-to-noise ratio and increase the BER of the return path system.

SIGNAL-TO-INGRESS RATIO

When using QPSK, the sum of all ingressing signals lying within the data signal bandwidth (approximately 1 MHz for the data signal as discussed in *SIGNAL-TO-NOISE RATIO* above) should be at least 20 dB below the level of the data signal.

As the sum of ingressing signals exceeds this level, the BER performance of the return path system is degraded. If ingress levels approach -10 dBc, communication may be seriously degraded.

A Balanced System

When the system is balanced, a signal on one branch is degraded equally by noise on ALL branches to the same node.

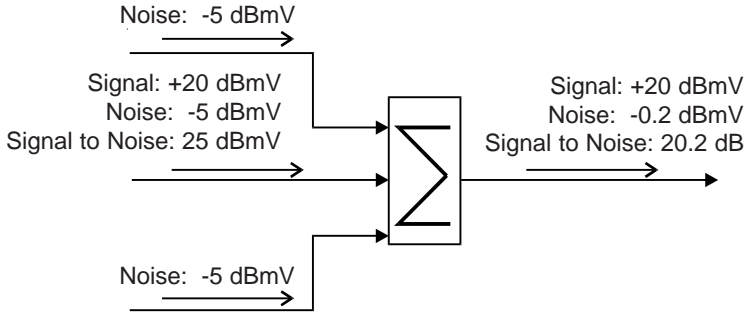

If, however, the gain of one path is set HIGHER than the others, its noise could disrupt traffic on ALL other paths.

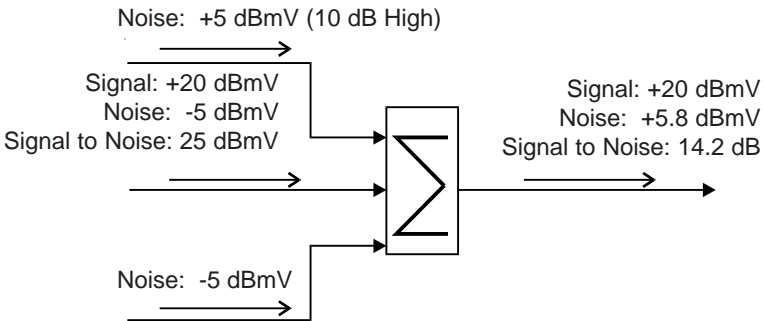

If the gain of one path is set LOWER than the others, its signals are disrupted by the noise of ALL other paths.

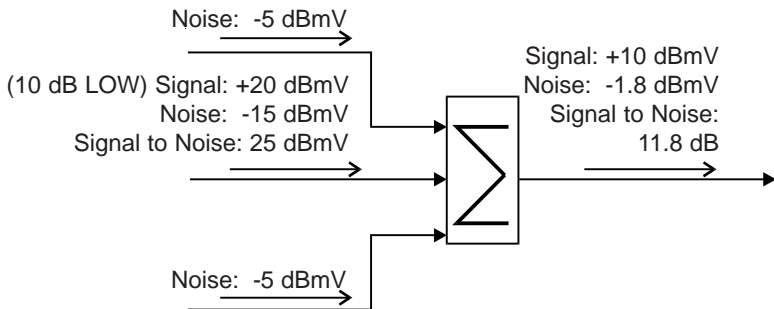

Figure 1. Balance Gain and Tilt.

ABOUT YOUR 9581 SST R3



9581 SST R3 System Overview

Your 9581 SST R3 Return Path Maintenance System is a single test system that enables you to deal with all aspects of return path upkeep; including both ingress control and system balancing. At the core of the system is the SST Unit, a 0.3 to 65 MHz digitizing spectrum analyzer, which is installed at the headend of your cable system.

The SST Headend Unit monitors all signals arriving at the headend, including reverse signal “traffic”, noise, ingress and test carriers from the SSR Field Unit(s).

A single SST Unit can monitor up to sixteen separate headend test points simultaneously which enables you to analyze the condition of each. The SST analyzes test signals and the return spectra separately. It packages measurement results into a data stream that it transmits to the SSR Field Unit(s).

The SSR's are addressed individually (A - F) which allows six of these units to be in operation on each TPM-8 at any one time. Each of these SSR Field Units transmits up to eight test carriers at user-settable frequencies. The SST measures these test carriers to compute the gain and tilt of the return path. The SSR's can store up to 24 sweep displays which can be reviewed at a later time or uploaded to a PC.

During system testing, the SST sorts out the test carrier measurements for each SSR and tags the data with the individual addresses (A – F) so that each SSR displays the appropriate information. When the SSR receives its data, it displays the response of the return path as either a line graph or as numeric values for gain and tilt. Ingress and noise data are presented as a spectrum analyzer display. For more information, refer to the manual which came with your 9580 SSR.

Theory of Application

The 9581 SST R3 test system can be used to:

- Balance the return path
- Measure the return path's ingress and noise

BALANCING THE RETURN PATH

In the basic test architecture, test signals are injected upstream by the SSR. These signals are measured automatically at the headend by the SST. Then, the measurement data is transmitted back to the SSR for the display.

In order to balance the return path of your system, you need to consider several alignment objectives. You need to set the fiber return path link to the system's design specifications. You must also set each line amplifier so that it will compensate for the gain and tilt of the cable and passives to the next amplifier.

The SSR has two types of displays which will accommodate amplifier adjustment differences:

- Eight-carrier line graph for amplifiers which require screwdriver adjustments.
- Calculated gain and tilt values for amplifiers which use pads and equalizers.

MEASURING INGRESS AND NOISE

In the basic test architecture, the SST Headend Unit's spectrum analyzer measures the incoming ingress and noise. It then transmits this measurement data to the SSR. The SSR displays the ingress data as a spectrum pattern.

REMINDER: If your 9581 SST R3 is equipped with the Test Point Manager option, you can analyze sixteen return paths individually.

When you are analyzing the return path, you need to determine if the return frequencies carrying “traffic” have an adequate signal/ingress ratio. To do this, you must first calculate the effective ingress power.

For narrow band ingress, such as CB or shortwave, measure the ingress power directly.

For broadband ingress, such as interference from machinery, treat the ingress as noise and correct for video or data bandwidth. In the formulas below, Measured Power (MP) equals the reading from the 9581 SST R3 and IP equals the effective Ingress Power.

To compute the effective noise in a 4 MHz video bandwidth, take the reading from the 9581 SST R3 and add 10.3 dB.

$$IP = MP + 10.3 \text{ dB}$$

To compute the effective noise for data bandwidth, take the reading from the 9581 SST R3 and add 10 times the log (data BW divided by .375MHz).

$$IP = MP + 10 \times \log (\text{data BW} / .375 \text{ MHz})$$

To maintain good picture quality, video signals require narrow band ingress to be between – 40 to 60 dBc, depending on the offset from the video carrier and broadband ingress to be at least – 40 dBc.

Quadrature Phase Shift Keying (QPSK) should have an effective ingress power of – 20 dBc for either type of ingress for a Bit Error Rate (BER) of approximately 1×10^{-6} .

HOT TIP

When the SST is setup according to this manual, it reserves about 15 dB of its amplitude measurement range to prevent the digitizer from being overloaded by powerful ingress transients. 10 dB of this “guardband” is visible as the top division on the SST’s spectrum display with an additional 5 dB above that. Experience has indicated that 15 dB is much more margin than is needed in all but the “dirtiest” systems. Up to 10 dB of the “guardband” can be reassigned to extend the SST’s measurement dynamic range. For more information, see EXTENDING THE MEASUREMENT RANGE on page 47.

INSTALLING THE 9581 SST R3

4

Introduction

You are now familiar with the theory behind return path alignment and maintenance so you can jump right in, turn on your 9581 SST R3 system and start optimizing that ole' return path. Actually, before you can even install your 9581 SST R3, you need to make decisions regarding carrier frequencies, which options you are using...you get the picture. The information in this chapter will assist you in making those pre-installation determinations and will show you how to install your SST Headend Unit. For information regarding the 9580 SSR unit, refer to the *9580 SSR/EU OPERATION MANUAL*.

The 9581 SST R3 uses a 3-conductor power supply cord which is rated at 1 A or greater. The cord should have an IEC320 connector which is the type approved as suitable for the application and acceptable to the regulatory authorities in the country where the unit is used.

The unit is identified with two IEC symbol labels. The back panel contains the symbol for alternating current (AC). The protective conductor terminal symbol label is inside the unit (see *SPECIFICATIONS* page 51).

SST Headend Unit Installation

You need to make several decisions concerning the location of the 9581 SST R3 as well as the placement and levels of the reverse test carrier and forward data carrier before you install your SST Headend Unit.

The 9581 SST R3 is designed to be rack-mounted so that it provides easy access to the power cord. Consideration should be given to ensure that the location provides a reliable protective earth connection, proper ventilation, and a stable environment.

WARNING: Use the equipment in the manner for which it has been designed in order to ensure proper operation.

The levels vary from one cable system to another depending on the characteristics of the signals already on your system. Several of the following decisions **REQUIRE** information concerning your system's design.

REVERSE TEST CARRIERS

You may choose up to eight reverse test carrier frequencies. Before making your selection, you should consider the following:

- Return band edges – usually the *highest* and *lowest* frequency test carriers will be near the return band edges (i.e. at 5 - 6 MHz and at 64 - 65 MHz).

NOTE: If you are using the 9580 SSR or the RSVP unit, your highest frequency is restricted to 41.5 MHz since these units only go as high as 42 MHz.

- Problem frequencies – a test carrier might be placed at a frequency in the return pass band where problems may occur due to the particular models of passives (taps, power inserters, etc.) which are being used in the system. For instance, some 750 and 1000 MHz passives have significant rolloff below 10 MHz. In this case, you might want to place test carriers around 5 and 10 MHz so that you can average the compensation for low end rolloff.
- Selected frequencies – you must avoid occupied bands of frequencies such as those carrying data or video. If you are using multiple SSR Field Units, you need to provide the following clear bandwidth **ABOVE** the frequency of each test signal.

Clear frequency BW = (number of SSR's – 1) x 100 kHz

However, if you plan to use the RSVP Installer Return Tester, you should set up one (or more) of the SST test frequencies close to the active frequency(ies) which will be used by the subscriber's equipment. Since the RSVP acts like a Unit F SSR, place the test carrier frequency which is to be used by the RSVP at least 500 kHz below the band edge of the active return frequency.

- The desired return signal output level is determined by the headend design.

This desired return output level **MUST** be established to set up the SST Headend Unit successfully. Consult the design documentation for your headend or calculate it based on the modem level requirements and the headend architecture to determine the correct figure.

- The actual return signal level arriving at the SST Headend Unit's INPUT port(s) must be equal to, or greater than, – 10 dBmV for accurate measurements over the full dynamic range of the SST. Include coupling losses and any in-line pads in your calculation.

NOTE: For signal-to-noise considerations, it is necessary that all fiber receivers sharing the same headend data modem have the same output level. For this reason, the SST expects to see the same return level at each return test point.

Levels before adjustment will differ due to the varying length of fiber to the node. One of the objectives for using the 9581 SST R3 is to balance receivers to the same output level; either through built-in adjustments or by inserting external padding, depending on the receiver's design.

FORWARD DATA CARRIER

You also need to define the characteristics for the forward data carrier. First, select a forward data carrier frequency.

- The carrier center frequency may be set below Channel 2 (50 – 53.75 MHz); in the Channel 4 – 5 gap (74 MHz band); or 80 – 92 MHz depending on the data carrier option installed. The frequency you select must be clear of other "traffic" for 200 kHz above and below the data carrier.

INSTALLATION PROCEDURE

Now that you have your system levels and frequencies determined, you are ready to install the your SST at the headend. Refer to Figure 2 below for the locations of the connections on the SST's rear panel.

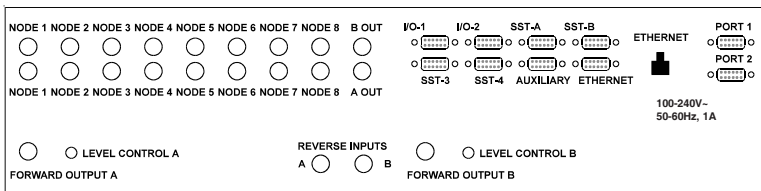
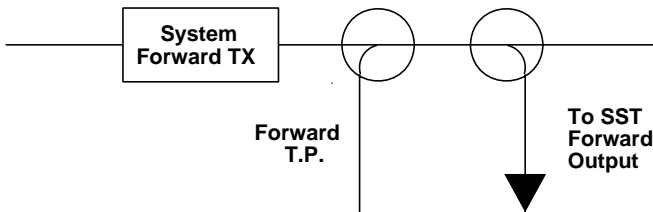

Figure 2. SST Headend Unit Rear Panel View.

Forward Connections

For forward connections, you need to provide a forward signal injection point. If necessary, install a 6 dB to 20 dB coupler before the forward test point.

Make sure that it is inserted in the proper direction.



REMINDER: The injection point must be BEFORE the Headend's forward output test point.

Reverse Connections

For reverse connections, you need to install test point couplers, in the range of 6 dB to 20 dB, at the outputs of the reverse path's fiber receiver outputs.

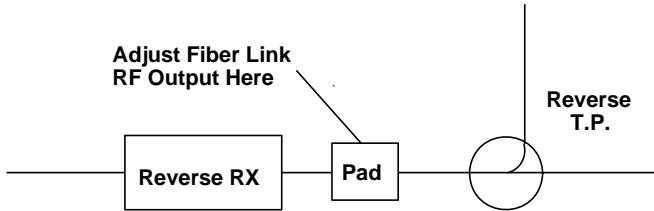

REMINDER: Note the coupler loss value. You will need to enter this data in the SST Headend Unit during the set up procedure. See *SET UP* page 23.

SST WITH TWO INPUT PORTS

If your SST Headend Unit has only two input ports, you may connect several test points simultaneously by summing them in an RF combiner. The noise from the combination will increase proportionately to the number of inputs which are combined.

SST WITH TEST POINT MANAGER OPTION

If your SST Headend Unit contains the Test Point Manager option, you can connect up to eight or sixteen test points individually to the SST Headend Unit's sixteen input ports.

NOTE: The value of coupling loss in the path between all fiber receiver outputs and inputs to the Test Point Manager **MUST** be the same for all sixteen test points.

For example, if a 12 dB coupler is used at one test point and a 6 dB coupler is used at another, you must insert an additional 6 dB pad between the coupler's tap port and the SST Headend Unit's input port.

SETTING UP THE 9581 SST R3



Introduction

Okay, you have installed the 9581 SST R3, you're all ready to power up and start using everything. Well, almost. Before you can operate the system, you need to perform several basic set up steps for both the SST and SSR Units (refer to *9580 SSR/EU OPERATION MANUAL* for SSR set up information).

The 9581 SST R3 contains two SST units (A and B) in a single enclosure. The two sets of eight banks each support six SSR Field Units for a total of twelve. Since the 9581 SST R3 contains two FSK transmitters, there is separate telemetry for the SST A and SST B.

9581 SST R3 Onscreen Help

The 9581 SST R3 provides help which is displayed onscreen. To access the help feature at any time, press the ? (HELP) button.



This displays a brief procedural description for the function or mode which the 9581 SST R3 is currently using.

To exit the HELP screen, press the **SELECT** button.



Power Up

Now you are ready to power up your SST.

NOTE: Make sure that the **FORWARD OUTPUT** of the SST is disconnected.

Connect the AC Power to the **AC INPUT** on the rear panel of the SST. Then plug the power cord into an outlet.

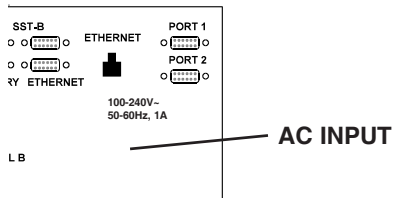

Once the SST Headend Unit is connected to the power source, turn it ON via the **ON/STANDBY** control button on the Unit's front panel. See Figure 3 below.

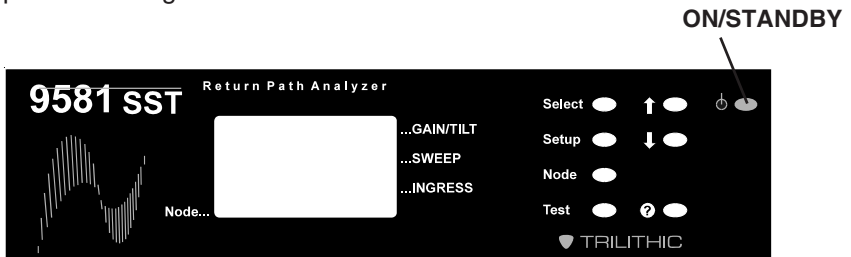

Figure 3. SST Headend Unit Front Panel View.

The SST will power up in the INTRO screen and then display the last test mode used.



Set Up

Now that the SST Headend Unit is connected and turned ON, you need to program its nonvolatile memory with several pieces of information:

- Return Sweep Frequencies
- Desired Return Level at the Headend
- Test Point Coupling Value
- Data Link Frequencies
- Data Link Levels (set on rear panel)

To enter the SETUP Mode, press the **SETUP** button on the front panel.



This will bring up the SET UP MENU in the Unit's display.

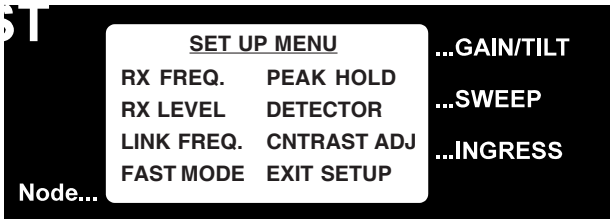

Once you are in the SET UP MENU, use the **ARROW** buttons to move from one selection to another.

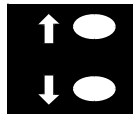

When the desired selection is highlighted, use the **SELECT** button to enter the SET UP SCREEN for that selection.

NOTE: If you wish to abort the set up selection, keep pressing the **SELECT** button. As long as you don't press the **ARROW** buttons, none of the function screens are changed.

RX FREQ

Use the **RX FREQ** selection to set the eight frequencies which the SSR will transmit for reverse alignment. Use the **ARROW** buttons to highlight RX FREQ.

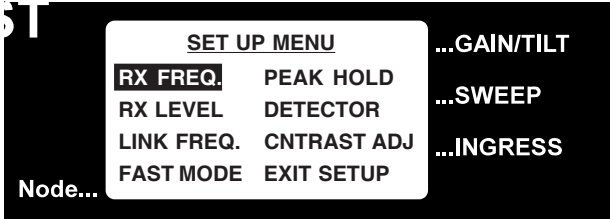

Then, press **SELECT** to enter the SET RX FREQS Menu.

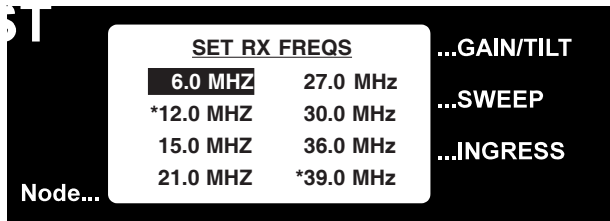

The eight test frequencies for SSR Field Unit “A” are displayed and the first frequency will be highlighted. Use the **ARROW** buttons to *increase or decrease* the test frequency.

NOTE: The test frequencies **MUST** be ranked in order with the **LOWEST** frequency at the top of the list and the **HIGH-EST** frequency at the bottom.

Once you have selected the desired frequency, you may press **SELECT** to highlight the field left of that frequency. Use the arrow keys to *toggle* an “*” on or off beside that frequency. Only two frequencies can be marked with an “*”. The SST uses the two marked frequencies to calculate the Gain/Tilt numbers which it displays. You must program the SSR’s Gain/Tilt separately (see page 35). It is a good idea to use the **SAME** frequencies for Gain/Tilt in both the SST and the SSR. To proceed to the next frequency, press **SELECT** again.

NOTE: When you have finished with the “*” field of frequency eight, pressing **SELECT** takes you to the RX FREQ for the “B” unit.

If you are using more than one SSR Field Unit, the other SSRs (“B” through “F”) space themselves automatically at 90 kHz intervals from the next lower unit. For example, if SSR Field Unit “A” is set for 5.0 MHz, “B” will use 5.09 MHz, “C” will use 5.18 MHz and so on. The frequencies for the SST Headend Unit “A” and Unit “B” are transmitted over the data link so that all units have access to the test frequencies.

HOT TIP

Each SST Headend Unit may have its own set of test frequencies. The SSR Field Units will change automatically to those frequencies when receiving that particular SST’s data signal. This is useful when return paths have different active frequencies which must be avoided when sweeping. The same test frequencies will be used on the TPMs for a given SST.

RX LEVEL

The SST Headend Unit must be told what level to expect from a reverse system which is operating properly.

To program the nominal reverse level desired at the headend or at the fiber receiver’s output, use the **ARROW** buttons to highlight RX LEVEL in the SETUP Menu.

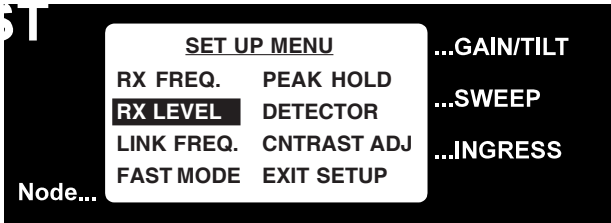

Press **SELECT** to enter the RX LEVEL Menu.

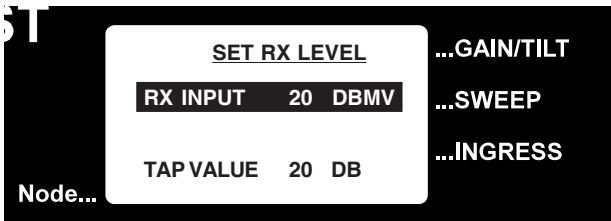

NOTE: The actual RF level at the SST input (RX Input – Tap Value) must be LESS than + 25 dBmV and GREATER than – 10 dBmV for proper operation of the SST.

With RX INPUT highlighted, use the **ARROW** buttons to *increase* or *decrease* the RX input value.

When the value is set, press **SELECT** and the highlight will scroll down to the TAP VALUE.

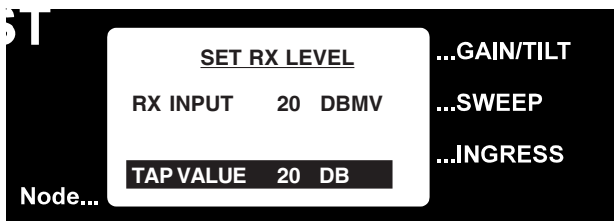

Use the **ARROW** buttons to enter the coupling losses if there are any between the reverse cable or fiber receiver and the SST Headend Unit. For example: if you are using a 20 dB coupler, enter 20 dB.

NOTE: For nominal levels greater than +15 dBmV, the tap value cannot be set lower than the minimum required to ensure that input levels for full scale will not exceed +25 dBmV.

When you are finished, press **SELECT** to return to the SETUP Menu.

NOTE: All displays on the SST and SSR Units will be referenced to the value entered for the RX INPUT.

LINK FREQ

Now you need to set the forward data carrier frequency. Use the **ARROW** buttons to highlight LINK FREQ. in the SETUP Menu.

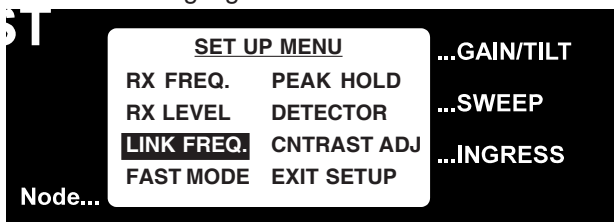

Press **SELECT** to enter the LINK FREQ. Menu.

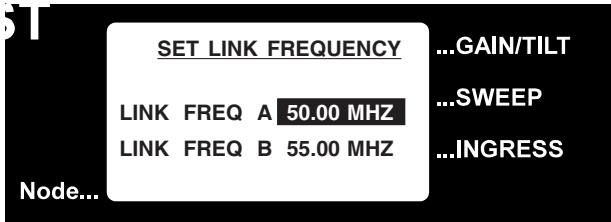

Use the **ARROW** buttons to *increase* or *decrease* the forward data carrier frequency for SST A. Then, press **SELECT** and use the **ARROW** buttons to set the frequency for SST B.

When you are finished, press **SELECT** to return to the SETUP Menu.

NOTE: All SSR Field Units operating in conjunction with each SST must be set to the same LINK FREQUENCY as the SST to which they are connected.

LINK LEVEL

Use the **LEVEL CONTROLS** (for SST A and SST B) on the rear panel to set the data link level between 0 and 10 dB below system video carrier levels when measured at the **FORWARD OUTPUT** connection on the unit (see Figure 4 below). Connect the 9581 SST R3 to the forward path injection point and repeat the adjustment while monitoring the level at the headend output test point.

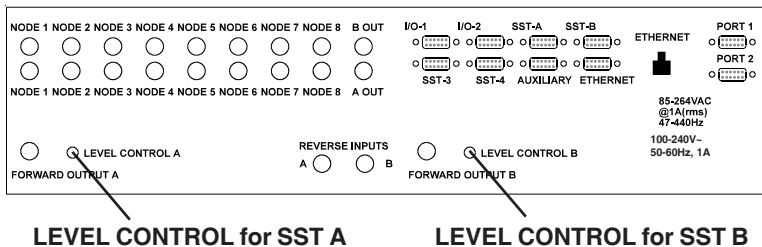

Figure 4. SST Headend Unit Rear Panel View.

FAST MODE

The SST supports two settings in FAST Mode:

- 375 kHz Resolution BW, 20 Hz/node sweep rate
- 525 kHz Resolution BW, 80 Hz/node sweep rate

FAST Mode increases the effective sweep rate of the ingress mode spectrum analyzer enhancing the ability of the 9581 SST R3 to capture transient ingress events. These events can be significant sources of ingress even in a well set up system.

NOTE: Sweep is NOT supported when the unit is in FAST Mode.

Use the **ARROW** buttons to highlight FAST MODE in the SETUP Menu.

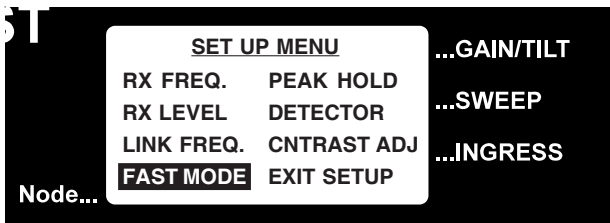

Press **SELECT** to enter the FAST MODE Menu.

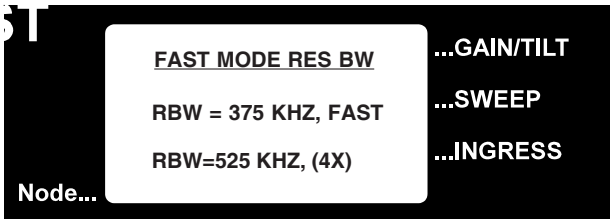

Use the **ARROW** buttons to highlight the desired Resolution BW setting. Press **SELECT** to return to the SETUP Menu. This mode is memorized so that when the power is cycled, the unit remembers the last setting and returns to it.

PEAK HOLD

The SST Headend Unit will peak hold its display in the SPECTRUM Mode. Use the **ARROW** buttons to highlight PEAK HOLD in the SETUP Menu. PEAK HOLD Mode enables the unit to display the highest ingress points until it is reset. When in this mode, the unit works in NORM and FAST Modes. It is useful for long duration tests for ingress on a particular node. PEAK HOLD affects the display on the SST only. It does not affect ingress sent to the SSR Field units or Ingress ManagR. This mode always resets to “OFF” when the unit is powered down.

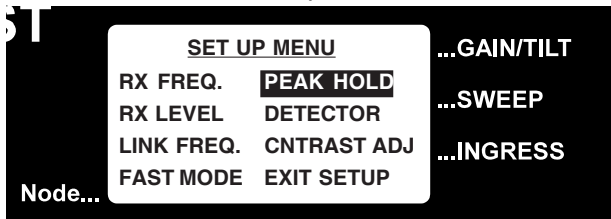

Press **SELECT** to enter the PEAK HOLD Menu.

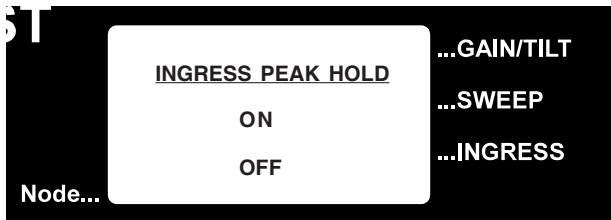

Use the **ARROW** buttons to highlight the desired peak hold status. Press **SELECT** to return to the SETUP Menu.

DETECTOR MODE

The 9581 SST R3 Headend Unit supports ingress detection schemes which are utilized in FAST Mode. The schemes are:

- Peak Detection - standard in all units
- Average Detection - optional (525 kHz FAST Mode only)
- TrafficControl - optional (525 kHz FAST Mode only)

You use the Peak Detection scheme to enable the SST to capture transient ingress events. The Average Detection scheme is used to reduce the noise floor displayed on the SST when measuring CW or common path. TrafficControl is used to filter out the “desired” signals so only the ingress spectrum remains.

Use the **ARROW** buttons to highlight DETECTOR in the SETUP Menu.

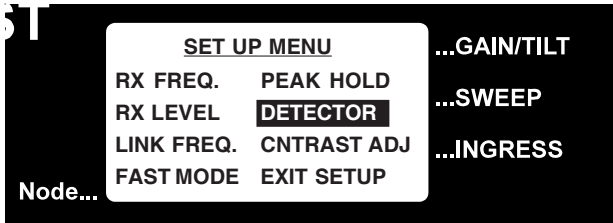

Press **SELECT** to enter the DETECTOR Menu.

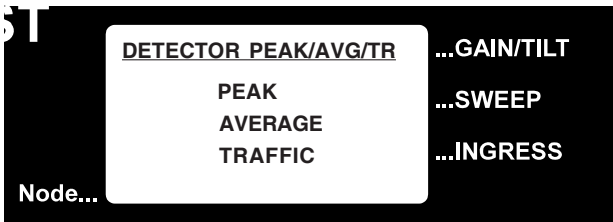

NOTE: You must have the TrafficController/Average Detector option installed in order to access the PEAK/AVG/TRAFFIC detector screen. If this option is not installed, when you select DETECTOR the display will indicate the following:

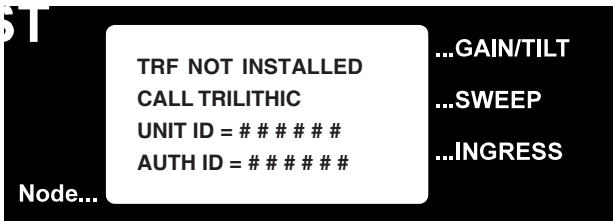

If you'd like to purchase the Average Detector option for your SST, please contact Trilithic at 1-800-344-2412. (In the above display, the UNIT ID will display the ID number of your particular unit. When you call, the customer service representative will give you a six-digit authorization ID code to activate the option in your unit.)

Use the **ARROW** keys to highlight the desired scheme. Once you have highlighted the desired mode, press **SELECT** to return to the SETUP MENU.

NOTE: The SST memorizes the selected scheme and will return to it even if the unit has been turned OFF.

When the PEAK or AVERAGE scheme is selected, the display in FAST Mode will indicate which detector scheme is enabled. For example, the word FAST changes to F-PK or F-AV (see page 36 for more information for FAST Mode).

If your 9581 SST R3 is equipped with TrafficController, you will be able to use it to strip the legitimate signals out of the return spectrum. This leaves a spectrum that is composed of only ingress and reverse noise. The processed spectrum is updated every 0.75 seconds and may be viewed on any PC running the latest version of Ingress ManagR as well as in the field via the 9580 SSR units.

ADJUST CONTRAST

The SST Headend Unit's display can be adjusted to your preference with regard to contrast. Use the **ARROW** buttons to highlight CNTRST ADJ in the SETUP Menu.

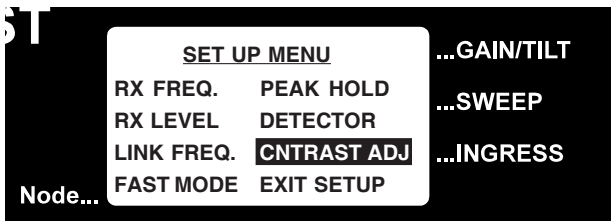

Press **SELECT** to enter the CNTRST ADJ Menu.

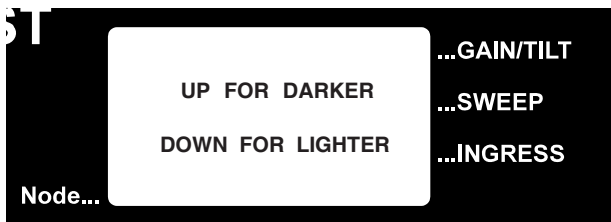

Use the **ARROW** buttons to *increase* or *decrease* the degree of contrast in your display.

When you are finished, press **SELECT** to return to the SETUP Menu.

EXIT SETUP MENU

When you have finished programming the SST Headend Unit's nonvolatile memory, highlight the EXIT SETUP option in the SETUP Menu. Press **SELECT** and the Unit will return to whatever mode it was in when SETUP was entered.

NOTE: If you press the ? (Help) button when EXIT SETUP is selected, the SST will display its software version data.

BASIC OPERATION



Introduction

Okay, you have reviewed the theory behind return path alignment and maintenance, installed and “prepped” your 9581 SST R3 and SSR Units (see *9580 SSR Operation Manual*), and set up the 9581 SST R3 according to the procedures in Chapter 5. Now you’re ready to start using your 9581 SST R3 system. In this chapter, you will learn how to perform basic operations. See Chapter 7 for information on system test and alignment procedures.

Sweep Mode

To select SWEEP Mode, use the arrow keys to select **SWEEP**.

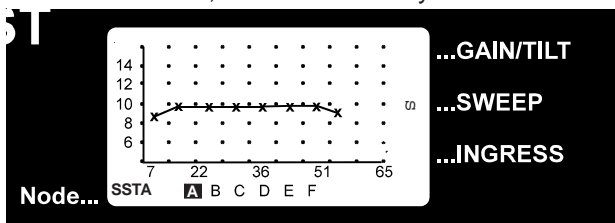

The Unit shows the sweep response for the SSR Field Units, defaulting to the last SSR Unit selected.

To view the response of a different SSR Field Unit, use the **SELECT** button to move from A through F until the desired Unit is highlighted.

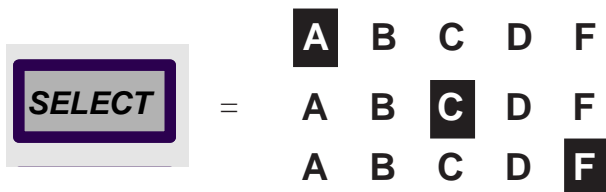

NOTE: When the SST Headend Unit detects interference at the sweep carrier frequency which is less than 20 dB below the sweep carrier level, it will warn you by placing an “X” at that data point instead of the bar “—” which is normally used.

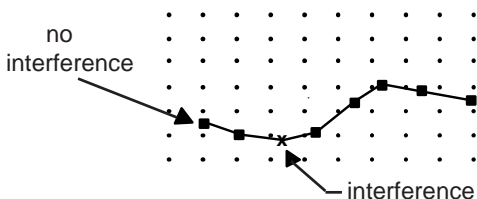

Gain/Tilt Mode

To select GAIN/TILT Mode, use the arrow keys to select **GAIN/TILT**.



The gain and tilt are displayed in numeric format along with the two sweep carrier frequencies which are used to compute the gain/tilt data. The display shows the gain and tilt for the Unit last selected in SWEEP Mode.

Gain represents the difference between the desired level which has been programmed into the SST Headend Unit and the actual return level found at the STOP frequency.

Tilt represents the STOP level minus the START level. The gain and tilt displayed by the 9581 SST R3 represents the SSR Field Unit which is currently selected under the SWEEP Mode.

REMINDER: The START and STOP frequencies are selected by the “*” in the SET RX FREQS SETUP Menu.

Spectrum Mode

The SPECTRUM Mode provides a handy way to monitor noise and ingress. To enter SPECTRUM Mode, use the arrow keys to select **INGRESS**.

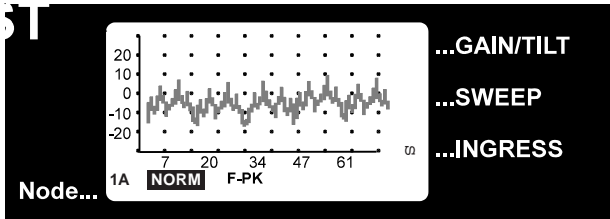

NOTE: The display defaults to NORM. You can use the **SELECT** button to cycle between NORM Mode and FAST Mode.



NOTE: The “XX” designation is used to denote which detector scheme is enabled, PEAK or AVERAGE (F-PK, F-AV).

If your 9581 SST R3 is equipped with the test point manager, the test point (node) being displayed appears in the lower left corner along with the SST unit (1A, 8B, etc). Each SST supports eight nodes. In the above sample display, NODE 1 of SST A is displayed as “**1A**” in the lower left corner by **NODE**.

NOTE: If you are using the optional Test Point Manager, press the **NODE** button to cycle through the 8 nodes of SST A. Continue to press **NODE** to proceed to SST B and its eight nodes.

When you wish to look at a specific input channel, press **NODE** until the desired input test point appears next to **INGRESS**.

NOTE: If you have PEAK HOLD enabled, “PK” appears above the NODE number in the lower left of the display. PEAK HOLD is reset whenever the node is changed or the mode is cycled to FAST.

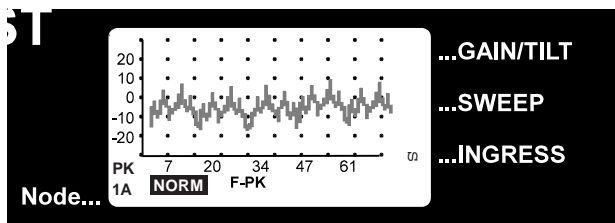

Fast Spectrum Mode

To enter FAST SPECTRUM Mode, press **SELECT** until FAST is highlighted. The unit’s display will look similar to the spectrum when it is in NORM Mode; however, the resolution bandwidth and sweep rate will be as indicated in the FAST MODE SETUP Menu.

The word FAST at the bottom of the display changes to reflect the current detector selection.

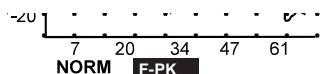

Peak Detection in
FAST Mode

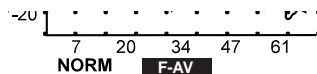

Average Detection in
FAST Mode

NOTE: If you are using the optional Test Point Manager, press the **NODE** button to cycle through the 8 nodes of SST A. Continue to press **NODE** to proceed to SST B and its eight nodes.

NOTE: You can NOT select the SWEEP or GAIN/TILT Modes while you are in FAST SPECTRUM Mode. To change to other modes, first press **SELECT** to return to the NORM Mode. Then use the **ARROW** buttons to select one of the other modes.

When you wish to look at a specific input channel, press **NODE** until the desired input test point appears next to **INGRESS**.

NOTE: If you have PEAK HOLD enabled, “PK” appears above the NODE number in the lower left of the display. PEAK HOLD is reset whenever the node is changed.

REMINDER: Your SST does not support SWEEP Mode when it is in FAST Mode. SSR Field Units with firmware version 2.00 or greater will be able to display ingress data when the SST is in FAST Mode. However, all sweeping and gain balancing activities will be halted until the SST returns to the NORM Mode. SSR’s with firmware version older than 2.00 will not display ingress data when the SST is in FAST Mode. If this causes problems, contact Trilithic to have your SSR upgraded.

Remote Mode

You may access your 9581 SST R3 via a PC.

NOTE: In order to use this feature, you must have the COMM MANAGER (NCM-4/ACM-8) option equipped in your 9581 SST R3.

When used in the REMOTE Mode, your 9581 SST R3 becomes a powerful status monitoring tool when used with **Ingress Manager** software. All of the displays that appear on the unit are also available remotely. Your SST Headend unit continues to operate normally when it is under the control of a remote operator. The effects of entering FAST Mode on SSRs are the same as if a local operator had pushed the buttons on the SST’s front panel.

REMINDER: The REMOTE Mode is only available when you have a Communications Manager (NCM-4/ACM-8). In this case, you can access data via a serial link to a PC or a communications link (modem, Ethernet or Fiber) and control several 9581 R3 SSTs (two via the NCM-4 for a total of 32 test points; and four via the ACM-8 for a total of 64 test points).

ADVANCED OPERATIONS



Introduction

The first step in developing a successful alignment and maintenance strategy for the return path depends on understanding what constitutes a properly operating system. If you have not already done so, review Chapter 5 for the data regarding your system parameters so that you will have the following information handy:

- Proper levels at the headend
- Proper injection points for the node and each type of amplifier in the system
- Proper injection level for each device in the return system including coupling and test probe losses

You may also wish to review Chapters 4 and 6 for the proper installation and basic operation of your 9581 SST R3 system as well as the *9580 SSR Operation Manual*.

Alignment of the reverse should begin at the headend. Use the SST to monitor the ingress for each return path that you will be aligning (refer to *SPECTRUM MODE* on page 35).

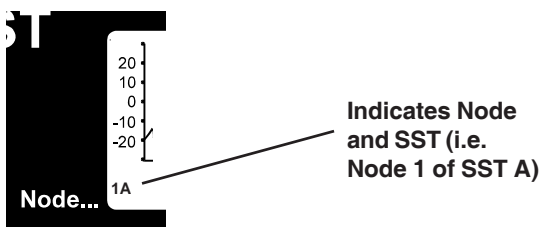

REMINDER: When you are reading the ingress, the 9581 SST R3 displays the node and the SST (A or B) it is reading. In the example above, NODE 1 of SST A is being read so **1A** appears next to the word “Node” on the front panel. To cycle through SST A nodes 1 - 8 and then proceed to SST B and its 8 nodes, press the **Node** button.

For the 9581 SST R3 system to achieve sweep accuracies better than ± 1 dB (and your return data system to function properly), ingress must be at least 20 dB below the expected return levels. If the SST is set properly, this will be 30 dB down from full scale on the ingress display. Carefully inspect the spectrum around each test carrier frequency. If ingress is excessive, take one of the following steps to reduce it:

- If you are combining several return paths, try disconnecting some to reduce total ingress.
- If your system has no active carriers, turn down the gain or remove the pads in the reverse amplifiers.
- Temporarily pick a higher operating level for the SST and SSR.
- Find and fix the major ingress problems. Remember, you can use your 9580 system to help you troubleshoot the ingress while in the field. See *INGRESS* on page 43.

If ingress exceeds -20 dB relative to the desired return level, the 9580 sweep display will show an “X” rather than the usual frequency marker (bar). This is another indication that there is an ingress problem which needs to be tracked down.

Adjusting the Fiber Link

Adjustment of the fiber link will require two technicians since the fiber receiver output must be adjusted with the SSR connected to the node (see Figure 5 below).

NOTE: This could be achieved with one technician but it would involve a lot of back and forth runs to the headend and the node.

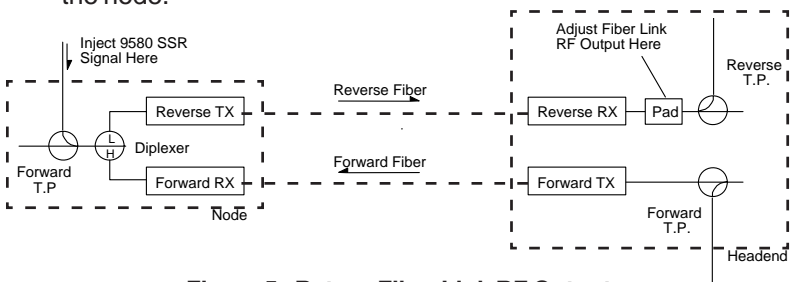

Figure 5. Return Fiber Link RF Output.

To adjust the fiber path properly, consult the manufacturer's data sheets to determine how to set gain in the fiber receiver. You may also want to measure the optical power at the receiver input to make sure that it meets recommended levels prior to starting alignment. Inject the 9581 SST R3 test signals at the system design level into the node test point.

If your fiber receiver uses pads to set the gain, use the **GAIN/TILT** display on the SST to determine the correct pad to use in the fiber receiver. The SST will show a maximum gain error of ± 9.9 dB. If the initial gain is off by more than ± 9.9 dB, it may be necessary to zero in on the correct pad by changing the pad value until the reading is on scale. Then you can select a pad accordingly to set the gain as close as possible to 0.0 dB. When finished, switch to the **SWEEP** display to observe the sweep response.

If your fiber receiver has a screw driver adjustment, use the **SWEEP** display and adjust the receiver's gain so that the sweep response is positioned on the center graticule of the **SWEEP** display.

HOT TIP

Be sure to select the proper Unit ID on the SST SWEEP display. Remember, this also effects which SSR's data is displayed in the GAIN/TILT display.

NOTE: Some fiber nodes have a gain adjustment in the node which must be set first (i.e. Texscan's FLAME-THROWER™). Consult the manufacturer for the proper procedure for making this adjustment prior to setting the fiber receiver's gain.

If you cannot get a display, try the following:

- Be sure that the SSR is receiving the data carrier as evidenced by the cursor pointing to **CAR DET** (carrier detect) on the SSR's display.
- Make sure that the injection test point you are using is pointing the correct way (i.e. TOWARD the headend).

- Make sure that the fiber transmitter and receiver are functioning properly and that the proper light level is reaching the headend.
- Increase or decrease the SSR's TX level in 5 dB increments until the response is on screen. Note the difference which is necessary for the output setting and adjust the gain accordingly. Now you can return your SSR to the proper output level and fine tune the gain setting.

Adjusting Amplifiers

When an amplifier is balanced properly, its gain and tilt will virtually cancel the loss and tilt of everything in the upstream path between the amplifier and the next amplifier upstream (see Figure 6 below).

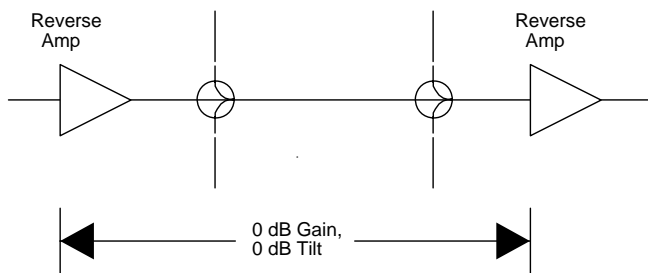

Figure 6. Balanced Amplifier.

With the node adjusted properly, proceed to the first amplifier from the node. Set your SSR's TX level to the proper injection level for the amplifier. Connect it to the amplifier's input test point(s).

REMINDER: Don't forget to allow for test point or coupling losses.

For amplifiers with fixed pads and equalizers, use the **GAIN/TILT** display. The 9581 SST R3 will show a maximum gain error of ± 9.9 dB. If the initial gain is off by more than ± 9.9 dB, it may be necessary to zero in on the correct pad by changing the pad value until the reading is on scale. Then you can install the equalizer to compensate for tilt. Once the tilt is corrected, fine tune the pad value to give an overall gain of 0.0 dB. Now, you can switch to the **SWEEP** display to observe the sweep response.

If your amplifier has screw driver gain and tilt adjustments, you need to use the **SWEEP** display and adjust the amplifier's gain controls so that the sweep response is positioned in the display. Adjust the amplifier's tilt for a flat response. Then you can fine tune the gain adjustment to position the sweep response on the center graticule of the display. You can switch to the **GAIN/TILT** display to confirm your settings numerically.

If you do not get a display, try the following:

- Be sure that the SSR is receiving the data carrier as evidenced by the cursor pointing to **CAR DET** (carrier detect) on the SSR's display.
- Make sure that the injection test point you are using is pointing the correct way (i.e. TOWARD the headend).
- Increase or decrease the SSR's TX level in 5 dB increments until the response is on screen. Note the difference which is necessary for the output setting and adjust the gain accordingly. Now you can return your SSR to the proper output level and fine tune the gain setting.

Proceed to the next amplifier and repeat the process until ALL of your amplifiers are aligned. Make sure that you adjust the SSR's TX level if necessary when you are changing amplifier types.

Ingress

Ingress along the return path can cause serious disruptions to a subscriber's cable service. This makes regular monitoring of ingress an essential part of a sound return maintenance strategy. The 9581 SST R3 was designed to provide you with a simple solution to reverse monitoring.

When you are using the 9581 SST R3 to monitor ingress, there are configuration trade-offs which you need to consider. The most important of these concerns the number of return paths connected to a single input on the SST. Combining your returns may economize on your hardware but it can make it far more difficult to localize on the source of ingress.

If you equip your 9581 SST R3 with Test Point Managers, you will be able to monitor 8 or 16 independent return test points. This can reduce the need to combine returns.

If ingress control is a “must”, as it is in the case of telephony or commercial data carrying, consider using more than one SST so that each return can be monitored separately.

You can also automate your ingress monitoring task by using **Ingress ManagerR**, the 9581 R3 SST’s Remote Monitoring Software, with a PC.

When ingress problems do occur, you can:

- Determine along which return path the ingress is coming. If necessary, disconnect the combined returns one at a time until you locate the “bad” one.
- Read and record ingress levels at several frequencies.
- Go to the node (first amplifier in an all coax system) and read the ingress at the node’s return input using an SLM.

CAUTION: Be careful to choose a test point that is looking downstream and NOT toward the headend (see Figure 7 below).

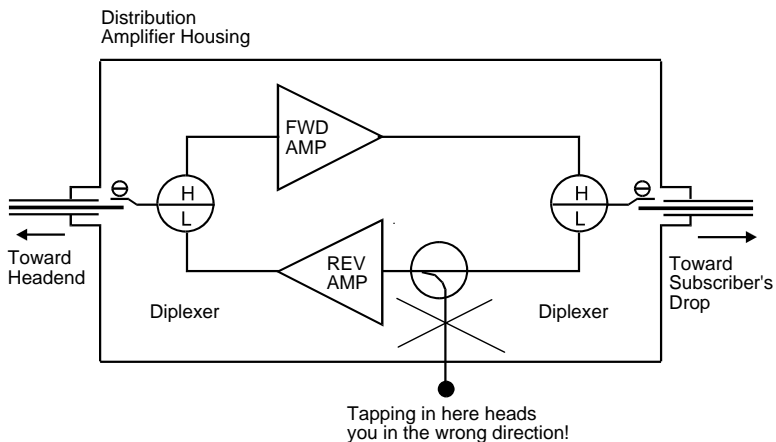

Figure 7. Incorrect Test Point Selection.

Compare this ingress to the levels you saw at the headend. If the levels are still about the same, divide the number of amplifiers in each leg in half and test at that point. Continue to divide the amplifier spans in half until you locate the amplifier farthest from the node that still has the ingress problem.

Once you have localized the ingress, you can troubleshoot the hardware and the drops of the target amplifier. When you think that you may have located the difficulty, connect the SSR to the system and verify that the problem is fixed by observing the ingress pattern.

Many ingress problems are transient in nature. For example, ingress from a CB radio will only be present when the radio is keyed on and the vehicle it is in is physically close to a leaky section of cable plant. These transient events will be on the order of 1 or 2 seconds.

Other events in the subscriber's house, such as electrical transients from turning on motors in appliances, can be much shorter in duration. The SST allows you to capture these transient events by combining the use of FAST Mode and PEAK HOLD Mode.

In FAST Mode, the SST analyzes each node at rates up to 80 Hz. This enables you to capture transients in the millisecond range.

When PEAK HOLD Mode is enabled, these transients stay in the screen until you reset the system.

REMINDER: The sweeping procedure is not supported when the SST is in FAST Mode.

An effective strategy for you may be to balance a node with the SST in NORMAL Mode. After you have obtained a balance, let the SST analyze the node in FAST Mode for a long duration (i.e. 24 hours) to verify that transient ingress is not a problem.



FEATURE NOTES

Interoperability

SSRs, and ACM-8s which have firmware version 2.00 or higher, are equipped with major new features which were not included in earlier firmware versions. While the firmware upgrades have been designed in such a way that the older and newer units will interoperate, you need to be aware that some of the more recent functions may not operate if you are using an earlier version of the 9580 SSR with the 9581 SST R3. Also, SSRs with firmware versions less than 4.00 have firmware and hardware limitations so that they can be used only to 42 MHz.

Extending the Measurement Range

When the SST is setup according to this manual, it reserves about 15 dB of its amplitude measurement range to prevent the digitizer from being overloaded by powerful ingress transients. 10 dB of this “guardband” is visible as the top division on the SST’s spectrum display with an additional 5 dB above that.

.....
15 dB
“Guardband”
.....

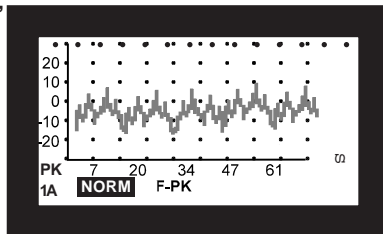

Experience has indicated that 15 dB is much more margin than is needed in all but the “dirtiest” systems. Up to 10 dB of the “guardband” can be reassigned to extend the SST’s measurement dynamic range. You can reassign the offset via a simple variation of the normal SST set up procedure. You will also need to adjust the 9580 SSR and RSVP units.

RECONFIGURE SST FOR GREATER RANGE

The SST evaluates system performance against a user-settable “reference level”. This is the “nominal” RF amplitude expected from a return fiber receiver when a test signal of the proper amplitude is injected into a return amplifier in the field. The SST automatically sets whatever reference level you choose to the middle of the display when it is in SWEEP Mode.

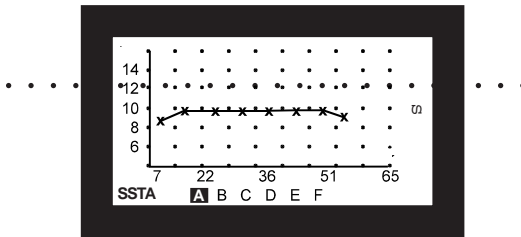

It also sets the level 10 dB BELOW the top of the display when in SPECTRUM Mode.

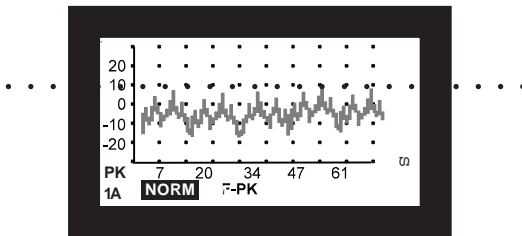

Increase Sensitivity and Range

To increase the sensitivity and range of the SST in SPECTRUM Mode, simply set the reference to a LOWER level. This enables the SST to “borrow” some of the operating “guardband”. In most systems, as much as 10 dB can be added to the SST’s operating range.

For example, suppose that the nominal return system reference level should be 20 dBmV. Setting the SST for a reference level of 10 dBmV recalibrates the SPECTRUM Mode display so that the 20 dBmV line is now at the TOP of the display rather than 10 dB below. The lowest level that can be observed now decreases to -20 dBmV. This increase in the SST’s measurement sensitivity is equal to the amount of the offset.

EFFECT OF OFFSET ON SSR UNITS

The reference settings for the SST's SWEEP and SPECTRUM Modes are linked. This means that offsetting the SPECTRUM Mode's reference level will also offset the reference for the SWEEP Mode by the same amount. To keep the SSR's "normal" sweep output from being TOO large, you simply need to reduce the SSR's sweep output level by the same offset amount.

NOTE: Regardless of the offset amount, the SPECTRUM display will read correctly.

EFFECT OF OFFSET ON RSVP UNITS

The RSVP measures the "launch level" from the subscriber's house and the carrier/noise ratio of the path back to the hub. If the SST's reference level is offset, the RSVP will report launch level and carrier/noise readings that are reduced by the amount of the offset. Measurements can be made by simply reducing the RSVP's launch level and C/N PASS/FAIL settings by the value of the offset.

Problems may occur when testing through low-value taps since the SST may instruct the RSVP to operate below its minimum output, 30 dBmV.

NOTE: The RSVP² has an extended range which enables you to test the return "launch level" through a wider range of tap and splitter values without using an external pad. The RSVP² has sufficient range to be connected directly to taps as low as 7dB; even in systems operating at reduced return levels or to services with as much as 35dB isolation, operating at normal levels. For more information, refer to the *RSVP² Operating Manual*.

This causes the RSVP to display a "FAIL" message and show a launch level below 30 dBmV. If this happens, you can insert a **return step attenuator pad** (such as an ARCOM RSA-xx) in line with the test jumper. This raises the RSVP's launch level to within its operating range. You then retest the launch level and subtract the pad value from the measurement.

For example:

At a house where the launch level is nominally 40 dBmV, offsetting the SST by 5 dB causes the RSVP to report a launch level of 35 dBmV.

At a house whose carrier/noise ratio is nominally 35 dB, offsetting the SST by 5 dB causes the RSVP to report a C/N of 30 dB.

This particular distribution system is designed to require a launch level of no more than 50 dBmV. Offsetting the SST's reference level by 5 dB reduces the maximum acceptable level to 45 dBmV.

At a house connected through a low-value tap, the RSVP reports a "FAIL" and shows a level reading of less than 30 dBmV. Insert an RSA-10 pad between the test jumper and the RSVP. Retest. The RSVP now gives a "PASS" reading. Subtract the value of the pad (in this example, 10 dB) from the displayed reading.



SPECIFICATIONS

9581 SST R3 SPECIFICATIONS

Frequency	0.375 – 65 MHz
Input Level Range (return test carriers)	+ 25 to – 10dBmV for full 50dB dynamic range in Spectrum Mode
Return Inputs	2 standard, 16 with two each Test Point Managers
Field Units supported	Up to 6 simultaneously per TPM
Sweep Mode	5 – 65 MHz with 0.25dB resolution
Sweep Mode Resolution BW	25 kHz effective
Input Level Accuracy	± 0.35 dB
Spectrum Display	50dB dynamic range from 10dB above to 40dB below nominal return level with 1dB measurement resolution
Spectrum Dispersion	Norm (0.375 – 65)
Resolution BW	375 kHz in Norm; 375 kHz in Fast (1x); 525 kHz in Fast (4x)
Sweep Rate	20 Hz/node in FAST; 80 Hz/node in 4X
Data Carrier TX Frequency	Standard: 80 - 90 MHz Optional: 50 to 53.75 and 70.00 to 75.75 MHz
Data Carrier TX Level	+ 23 to + 55dBmV continuously adjust- table
Data Carrier Spurious	– 60dBc

9581 SST R3 SPECIFICATIONS

(Continued)

Modulation	FSK with 38.4 kbps data rate
Data Carrier B.W.	150 kHz at – 20dBc, 475 kHz at –60dBc
Remote Access	Via RS-232, modem or Ethernet for all displays (with appropriate Communications Manager)
Display	64 x 128 pixel graphic LCD w/backlight
Power Cord	3-conductor rated at 1A with IEC320 connector
Power Requirement	100-240~ (alternating current), 50-60Hz, 1A
Protective Conductor Terminal Label	
Temperature	10 - 50°C
Dimensions:	3.5" x 17" x 12.3" 10 lbs (4.5kg) with all options



TRILITHIC

Trilithic is a privately held manufacturer founded in 1986 as an engineering and assembly company that built and designed customer-directed products for telecommunications, military and industrial customers. From its modest beginnings as a two-man engineering team, Trilithic grew over the years and broadened its offerings of RF and microwave components by adding broadband solutions to its product line. This was accomplished with the acquisition of components manufacturer Cir-Q-Tel and instruments manufacturer Texscan.

Today, Trilithic is an industry leader providing telecommunications solutions for major broadband, RF and microwave markets around the world. As an ISO 9000:2001 certified company with over 40 years of collective expertise in engineering and custom assembly, Trilithic is dedicated to providing quality products, services and communications solutions that exceed customer expectations.

Trilithic is comprised of three major divisions:

- **Broadband Instruments & Systems**

Offers test, analysis and quality management solutions for the major cable television systems worldwide.

- **RF Microwave Components**

Provides components and custom subsystems for companies specializing in cellular, military and other wireless applications.

- **Emergency Alert Systems**

Leading supplier of government-mandated emergency alert systems used by HFC service providers.

Trilithic, Inc.
9710 Park Davis Drive
Indianapolis, IN 46236
(317) 895-3600
(800) 344-2412

TWO YEAR WARRANTY

Trilithic, Inc. warrants that each part of this product will be free from defects in materials and workmanship, under normal use, operating conditions and service for a period of two (2) years from date of delivery. Trilithic, Inc.'s obligation under this Warranty shall be limited, at Trilithic, Inc.'s sole option, to replacing the product, or to replacing or reporting any defective part, F.O.B. Indianapolis, Indiana; provided that the Buyer shall give Trilithic, Inc. written notice.

Batteries are not included or covered by this Warranty.

The remedy set forth herein shall be the only remedy available to the Buyer under this Warranty and in no event shall Trilithic, Inc. be liable for incidental or consequential damages for any alleged breach of this Warranty. This Warranty shall not apply to any part of the product which, without fault of Trilithic, Inc., has been subject to alteration, failure caused by a part not supplied by Trilithic, Inc., accident, fire or other casualty, negligence or misuse, or to any cause whatsoever other than as a result of a defect.

Except for the warranty and exclusions set forth above, and the warranties, if any, available to the Buyer from those who supply Trilithic, Inc., there are no warranties, expressed or implied (including without limitation, any implied warranties of merchantability of fitness), with respect to the condition of the product or its suitability for any use intended for it by the Buyer or by the purchaser from the Buyer.



TRILITHIC
INNOVATIVE ENGINEERING

9710 Park Davis Drive
Indianapolis, IN 46236
(317) 895-3600