



# *INSTALLATION AND OPERATION MANUAL*

**Messenger-II**

Revision 1.00

PART NUMBER: 0010214000



**The Best Thing on Cable**



## Table of Contents

Introduction .....	1
Product Description.....	1
Video .....	1
Audio .....	2
RS-485 Data.....	3
Installation .....	4
Messenger-II with Baseband Audio .....	4
Messenger with 4.5 MHz audio.....	5
Specifications.....	6
Functional.....	6
Video .....	6
Baseband Audio .....	6
4.5 MHz Audio.....	6
Miscellaneous.....	7

## Illustrations

Figure 1 Messenger-II Character Generator with Baseband Audio .....	1
Figure 2 Detail of Messenger-II with Baseband Audio .....	2
Figure 3 Detail of Messenger-II with 4.5 MHz Audio .....	3
Figure 4 Installation of Messenger-II with Baseband Audio .....	4
Figure 5 Installation of Messenger-II with 4.5 MHz Audio.....	5



# Messenger-II

## Introduction

The Messenger-II provides six character generators in an addressable, single rack mount package. The Messenger-II character generators are used to display a crawl or text message over an existing video signal. Each character generator includes an audio switch to replace the normal audio source with an alternate audio. Baseband stereo or 4.5Mhz audio options are available. The AUDIO IN is high impedance with a loop through, allowing for multiple Messenger-II units to be supplied with a single audio line. The Messenger-II is controlled via an RS-485 line, allowing for up to 255 units on a single line. Additionally, each Messenger-II channel can be programmed with a unique address to allow for individual control of the character generators.

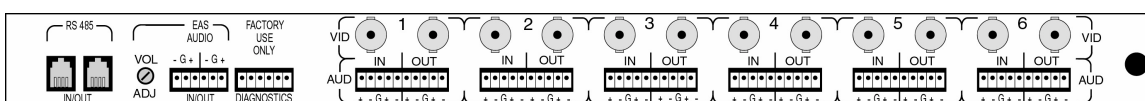

Figure 1 Messenger-II Character Generator with Baseband Audio

## Product Description

### Video

The Messenger-II character generators create and display text over an existing video signal, or as a stand-alone video source. Sync information is stripped off of the incoming baseband video and is used to determine the proper timing required to key characters over the video. Only baseband video may be fed into the Messenger-II units. Characters can be displayed over an existing baseband video signal or as a stand-alone video source. In the absence of incoming video, the Messenger-II generates an RS-170 NTSC video signal. This allows for continued message generation in the event of video signal loss. It allows the Messenger-II to operate as a stand-alone video source. A "Trouble Page" is available which can be programmed to automatically display a warning message in the event that the incoming video is lost.

The Messenger-II character generators can display a text message as a static page, a crawl, or both static text and a crawl. A static text page is defined as eleven rows of text, with 26 characters per row. A crawl message can contain up to 4000 characters. The character generators are capable of displaying a crawl while simultaneously displaying ten lines of static text (the crawl is considered to be a row of text). The crawl can be placed on any of ten user-defined rows, and can be programmed to repeat up to 99 times (or continuous). Character colors are selectable as black or white, and the background color can be black, gray, or transparent (characters are keyed directly over the incoming video). Each character generator is capable of locally storing up to six pages of static text and a 4000 character crawl.

The Messenger-II provides Fail-Safe video operation by routing the incoming video across hard relay contacts to either the character generator circuitry or to the program video output port. This safeguards against the loss of program video in the event of a device failure or power outage. Fail-Safe mode may also be continuously selected to prevent signal degradation by avoiding any active circuitry unless a text message is in process.

## Audio

The Messenger-II includes an audio switch with every character generator channel. This allows an alternate audio source to be switched into the channel during a character generator message. Each channel has an Audio Input Port and an Audio Output Port. Audio is normally routed directly from the Input Port to the Output Port across hard relay contacts. This ensures a fail-safe path for the program audio that is fed into the character generator channel. The channels' audio will always default back to this path in the event of a device failure or power outage. The Messenger-II provides one auxiliary audio input port (labeled "EAS AUDIO IN/OUT"). This signal is distributed to the auxiliary contacts of all six audio switches within the Messenger-II. The auxiliary audio port is a high impedance loop-through, allowing for up to 16 Messenger-IIs to be daisy-chained to a single audio source. The audio switches are controlled via RS-485 data. Each character generators' audio switch can be independently controlled.

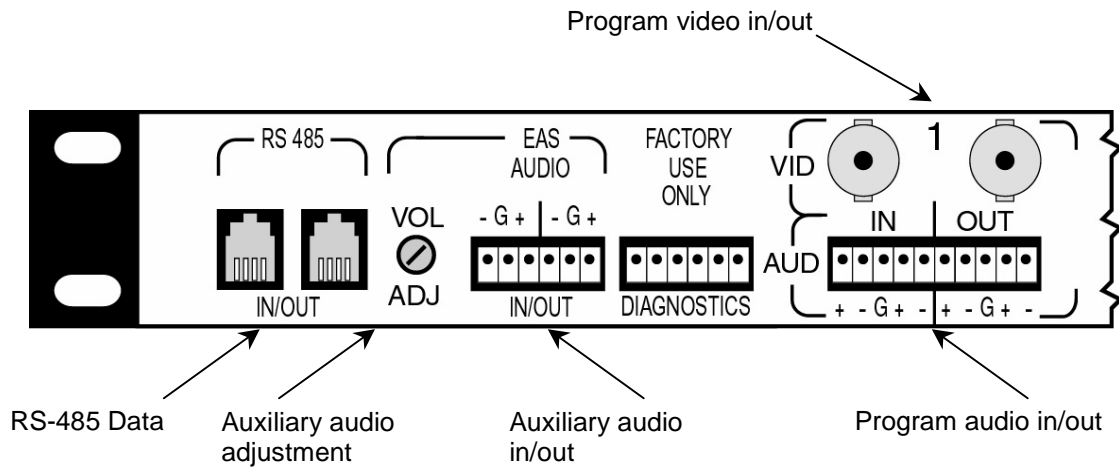

**Figure 2 Detail of Messenger-II with Baseband Audio**

The Messenger-II with baseband audio includes a 600Ω balanced stereo audio switch with every character generator channel. A single auxiliary audio input (balanced mono) is provided with each Messenger-II unit (one auxiliary input per six character generators). The auxiliary audio input is a high impedance (10KΩ) loop-through, allowing for up to 16 Messenger-IIs to be daisy-chained to a single audio source. A volume adjustment (labeled "VOL ADJ") is provided to balance the auxiliary audio with the program audio level.

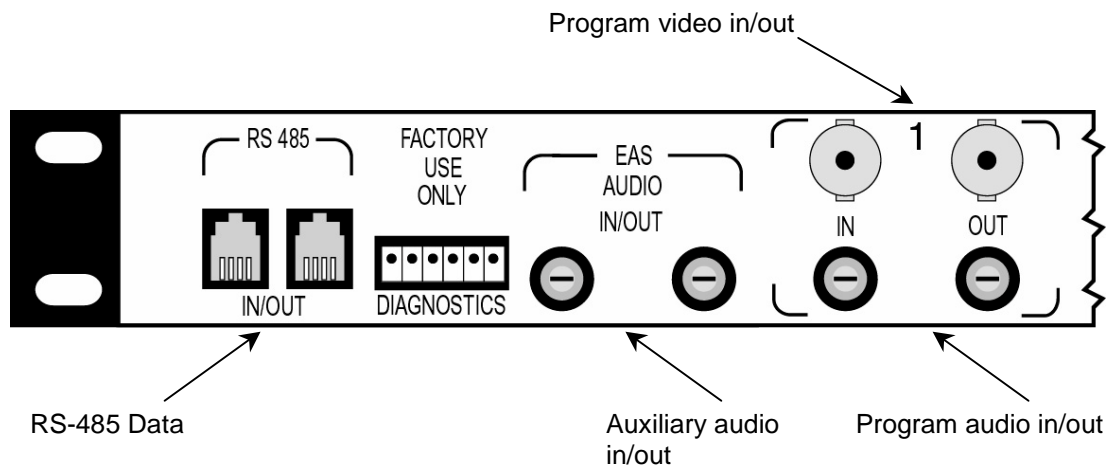

**Figure 3 Detail of Messenger-II with 4.5 MHz Audio**

The Messenger-II with 4.5MHz audio includes a 4.5MHz audio switch with every character generator channel. A single 4.5MHz auxiliary audio input is available for an alternate audio source (one auxiliary input per Messenger-II). This auxiliary audio input is a high impedance (200K $\Omega$ ) loop-through, allowing for up to 16 Messenger-IIs to be daisy-chained to one 4.5MHz audio source. NOTE: The last device in the chain must be terminated with a 75 $\Omega$  terminator.

### RS-485 Data

The Messenger-II character generators utilize the RS-485 communications protocol. The RS-485 data is balanced half duplex. It allows for up to 255 devices to be controlled by a single data line. RS-485 data is daisy-chained to each Messenger-II in the system (255 maximum). The last device in the chain must be terminated with a 120 $\Omega$  terminator. The communication protocol allows each character generator to be addressed globally (all generators on the data line), individually, or in groups. Each character generator can be programmed with a unique address for individual control. Additionally, a group address can be programmed into each character generator, allowing groups of channels to be controlled. The Messenger-II also provides status queries for troubleshooting and device status information.

# Installation

## Messenger-II with Baseband Audio

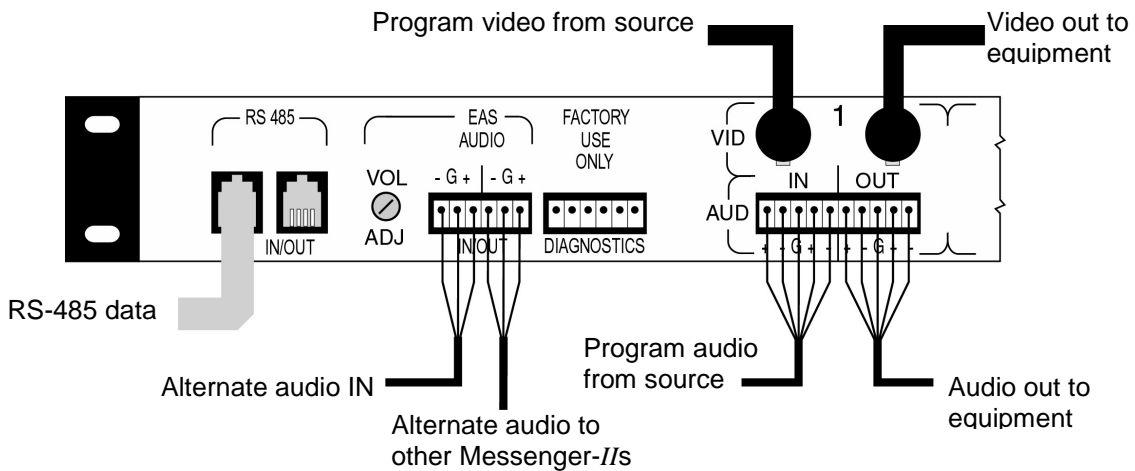

**Figure 4 Installation of Messenger-II with Baseband Audio**

Connect an audio wire from the alternate audio source to the Messenger-II *EAS AUDIO IN*. The remaining Messenger-IIs can then be daisy-chained to the same audio source by routing the *EAS AUDIO OUT* to the next Messenger-II *EAS AUDIO IN*. A maximum of 16 character generators may be daisy-chained together.

For each channel, attach the audio source to the MESSENGER-II *AUDIO IN*. Then route an audio cable from the Messenger-II *AUDIO OUT* to the *AUDIO IN* on the video equipment. Do this for both right and left audio, observing polarity and stereo separation.

For each character generator channel, attach the video source to the MESSENGER-II *VIDEO IN*. Then attach a cable from the Messenger-II *VIDEO OUT* to the *VIDEO IN* on the video equipment.

**NOTE:** The Messenger-II **MUST** be placed in the video line **BEFORE** any scrambling technology.

Attach a data cable from the controlling device to the *RS-485 IN* on the Messenger-II. The remaining Messenger-II units must then be daisy-chained to the RS-485 line by routing a data cable from the *RS-485 OUT* to the next Messenger-II *RS-485 IN*. Install the supplied terminator to the *RS-485 OUT* on the last Messenger-II.

**CAUTION:** The data cable supplied is for use with RS-485 data. **DO NOT** use telephone cable. Failure to use the correct cable will result in improper operation.

## Messenger with 4.5 MHz audio

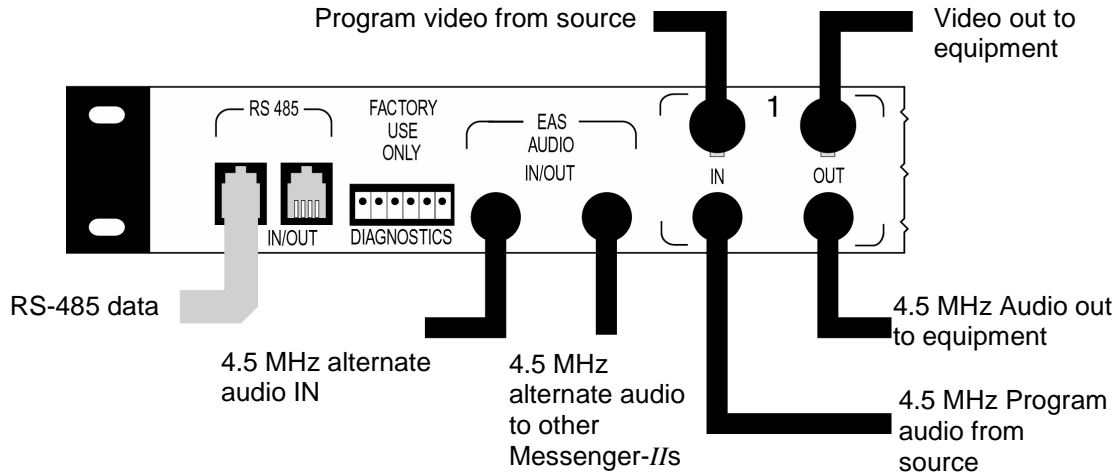

**Figure 5 Installation of Messenger-II with 4.5 MHz Audio**

Installation of the Messenger-II with 4.5 MHz audio is identical to the baseband audio version, except the audio switches utilize 4.5 MHz audio.

**NOTE:** The 4.5 MHz *EAS AUDIO OUT* on the EAS audio loop-through must be terminated with a 75Ω terminator. If multiple Messenger-IIs are to be installed the terminator must be placed at the last device in the chain.

# Specifications

## Functional

<b>Display:</b>	11 rows per page, 26 characters per row.
<b>Color:</b>	White, grey or black characters, with or without black edge.
<b>Fonts:</b>	Pixel resolution of 127 ns. 36 raster lines high (maximum). Standard ASCII with special characters.
<b>Background:</b>	Selectable black or grey.
<b>Page:</b>	11 rows of static display with or without a background.
<b>Crawl Display:</b>	Crawl speed - one. Crawl display - rows 2 through 11. Length - 4000 characters maximum. Repeat - up to 99 times (or continuous) with inter-delay. Static characters - 10 rows in addition to crawl.
<b>Static Display:</b>	11 rows of 26 characters.

## Video

<b>Video Input:</b>	BNC connector, 1 Vpp 75 $\Omega$ (resistive termination)
<b>Video Output:</b>	BNC connector, 1 Vpp 75 $\Omega$ (source termination)
<b>Passband:</b>	DC to 5 MHz
<b>Differential Gain:</b>	0.1% Maximum
<b>Differential Phase:</b>	$\pm .1^\circ$ Maximum
<b>Return Loss:</b>	25 dB or Better
<b>Insertion Loss:</b>	0.1 dB or Better
<b>Channel Isolation:</b>	60 dB or better at 3.58 MHz
<b>Video Switching:</b>	Fail-safe relay contact
<b>Sync/Genlock:</b>	Stand-alone RS-170 (monochrome) sync. Operational without external sync or program video. Automatic genlock to incoming video.

## Baseband Audio

<b>Program Audio Input:</b>	600 $\Omega$ balanced stereo program input.
<b>Program Audio Output:</b>	600 $\Omega$ balanced stereo program output.
<b>EAS Audio Input:</b>	High impedance input allows for 16 daisy-chained units from a single 600 $\Omega$ source.
<b>Audio Passband:</b>	20 Hz to 20 kHz
<b>Insertion Loss:</b>	0.1 dB or Better
<b>Passband Flatness:</b>	0.1 dB or Better
<b>Distortion (THD):</b>	0.1% or Better
<b>Audio Switching:</b>	Fail-safe relay contact

## 4.5 MHz Audio

<b>Program Audio IN/OUT:</b>	F-connector 1Vpp 75 $\Omega$ external termination.
<b>EAS Audio IN/OUT:</b>	F-connector 1Vpp 200K $\Omega$ to allow up to 16 daisy-chained units. Last device must have 75 $\Omega$ termination.
<b>Passband:</b>	DC to 5 MHz
<b>Insertion Loss:</b>	0.1 dB or Better
<b>Isolation:</b>	60 dB or better at 4.5 MHz
<b>Return Loss:</b>	25 dB or Better
<b>Audio Switching:</b>	Fail-safe relay contact

**Miscellaneous**

Control Data IN/OUT: RS-485 half duplex at 9600 baud.  
CG Addressing: 1000 user programmable addresses. (Address 000 and 999 reserved for special functions.)  
Mechanical: Rack mountable chassis 17" X 12" X 1U.







**Trilithic**  
**9202 East 33<sup>rd</sup> Street**  
**Indianapolis, Indiana 46235**  
**317-895-3600**